

LECTURE NOTES

ON

SWITCH GEAR AND PROTECTIVE DEVICES

6TH SEMESTER

PREPARED BY

JASOBANTA BARIK

PTGF IN ELECTRICAL ENGINEERING DEPARTMENT,

GOVERNMENT POLYTECHNIC, PURI

UNIT-1

INTRODUCTION TO SWITCHGEAR

Essential Features of switchgear:

What is Switchgear?

The apparatus used for switching, controlling and protecting the electrical circuits and equipment is known as switchgear.

The essential features of switchgear are:

1. Complete Reliability
2. Absolutely certain discrimination
3. Quick operation
4. Provision for manual control
5. Provision for instrument

1. Complete reliability

With the continued trend of interconnection and the increasing capacity of generating stations, the need for reliable switchgear has become of paramount importance.

This is not surprising because it is added to the power system to improve reliability. When a fault occurs on any part of the power system, they must operate to isolate the faulty section from the remainder circuit.

2. Absolutely certain discrimination

When a fault occurs on any section of the power system, the switchgear must be able to discriminate between the faulty section and the healthy section.

It should isolate the faulty section from the system without affecting the healthy section. This will ensure continuity of supply.

3. Quick operation

When a fault occurs on any part of the power system, the switchgear must operate quickly so that no damage is done to generators, transformers and other equipment by the short-circuit currents.

If the fault is not cleared quickly, it is likely to spread into healthy parts, thus endangering complete shutdown of the system

4. Provision for manual control

Switchgear must have provision for manual control. In case the electrical (or electronics) control fails, the necessary operation can be carried out through manual control.

5. Provision for instrument

There must be provision for instrument which may be required. These may be in the form of ammeter or voltmeter on the unit itself or the necessary current and voltage transformer for connecting to the main switchboard or instrument panel.

Switchgear Equipment:

Switchgear covers a wide range of equipment concerned with switching and interrupting currents under both normal and abnormal conditions. It includes switches, fuses, circuit breakers, relays, current transformer, and other equipment.

Read switchgear in the substation for more details.

A brief account of these devices is given below.

1. Switches

A switch is a device which is used to open or close an electrical circuit in a convenient way. It can be used under full-load or no-load conditions but it cannot interrupt the fault currents.

When the contacts of a switch are opened, an arc is produced in the air between the contacts. This is particularly true for circuits of high voltage and large current capacity.

The switches may be classified into

1. air switches
2. oil switches

The contacts of the former are opened in the air and that of the latter is opened in oil.

Air-break switch – It is an air switch and is designed to open a circuit under load. In order to quench the arc that occurs on opening such a switch, special arcing horns are provided. Read different types of air break switch.

Isolator or disconnecting switch – It is essentially a knife switch and is designed to open a circuit under no load.

Oil switches – As the name implies, the contacts of such switches are opened under oil, usually transformer oil.



Air break switch

2. Fuses

A fuse is a short piece of wire or thin strip which melts when excessive current flows through it for sufficient time. It is inserted in series with the circuit to be protected.

When a short circuit or overload occurs, the current through the fuse element increases beyond its rated capacity. This raises the temperature and the fuse element melts (or blows out), disconnecting the circuit protected by it.

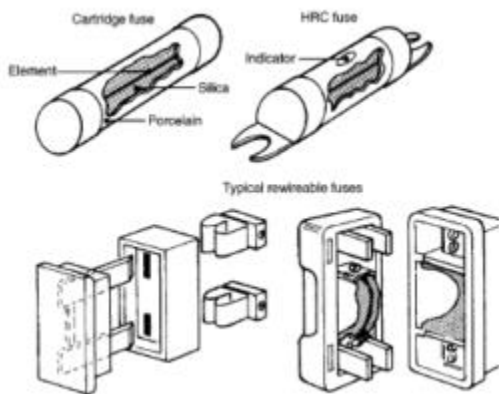

Fuse

3. Circuit Breakers

A circuit breaker is an equipment which can open or close a circuit under all conditions viz. no-load, full load and fault conditions. It is so designed that it can be operated manually (or by remote control) under normal conditions and automatically under fault conditions. For the latter operation, a relay circuit is used with a circuit breaker.

Low Voltage Circuit Breakers: Miniature Circuit Breaker, Moulded Case Circuit Breaker, Residual Current Circuit Breaker, Ground Fault Circuit Interrupter

High Voltage Circuit Breakers: Vacuum Circuit Breaker, SF6 Circuit Breaker, Oil Circuit Breaker, Air Blast Circuit Breaker

Read Circuit Breaker – Operating Principle and Arcing Phenomenon.

4. Protective Relays

Protective relays are vital parts of the switchgear equipment.

A relay is a device which detects the fault and supplies information to the breaker for circuit interruption.

The function of a protective relay is to initiate a signal to circuit breakers for disconnecting the elements of the power system when it develops a fault.

When a fault occurs the relay contacts are closed and the trip coil of the circuit breaker is energized to open the contacts of the circuit breaker.

5. Instrument Transformers

Instrument transformers are used in switchgear installations for the measurement of electrical parameters for protection and metering purposes.

An instrument transformer in which the secondary current is substantially proportional to the primary current and differs in phase from it by approximately zero degrees is called a **current transformer (CT)**.

A **voltage transformer (VT)** is an instrument transformer in which the secondary voltage is substantially proportional to the primary voltage and differs in phase from it by approximately zero degrees.

Bus-Bar Arrangement:

Definition: An electrical bus bar is defined as a conductor or a group of conductor used for collecting electric power from the incoming feeders and distributes them to the outgoing feeders. In other words, it is a type of electrical junction in which all the incoming and outgoing electrical current meets. Thus, the electrical bus bar collects the electric power at one location.

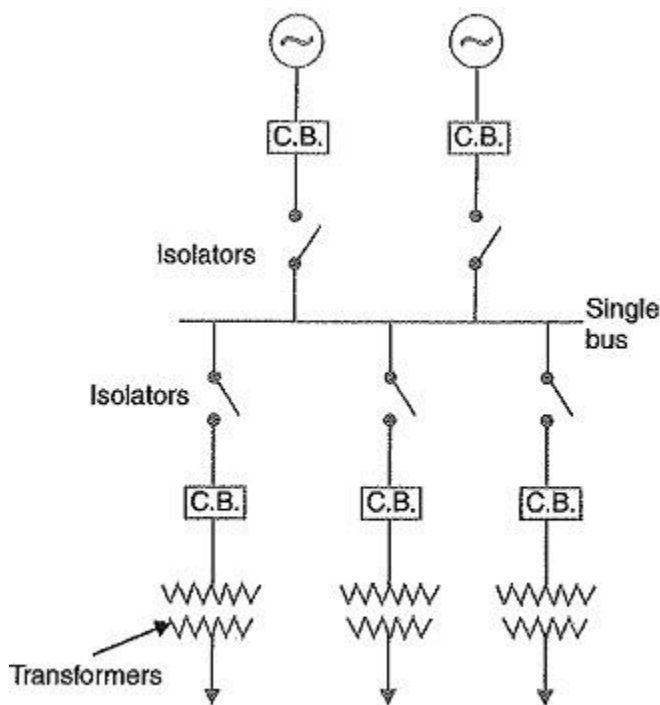

Fig. 16.2

Drawbacks of Single Bus-Bars Arrangement

- The only disadvantage of such type of arrangement is that the complete supply is disturbed on the occurrence of the fault.
- The arrangement provides the less flexibility and hence used in the small substation where continuity of supply is not essential.

Single bus-bar system with sectionalisation:

In this type of busbar arrangement, the circuit breaker and isolating switches are used. The isolator disconnects the faulty section of the busbar, hence protects the system from complete shutdown. This type of arrangement uses one additional circuit breaker which does not much increase the cost of the system.

As shown in fig16.3

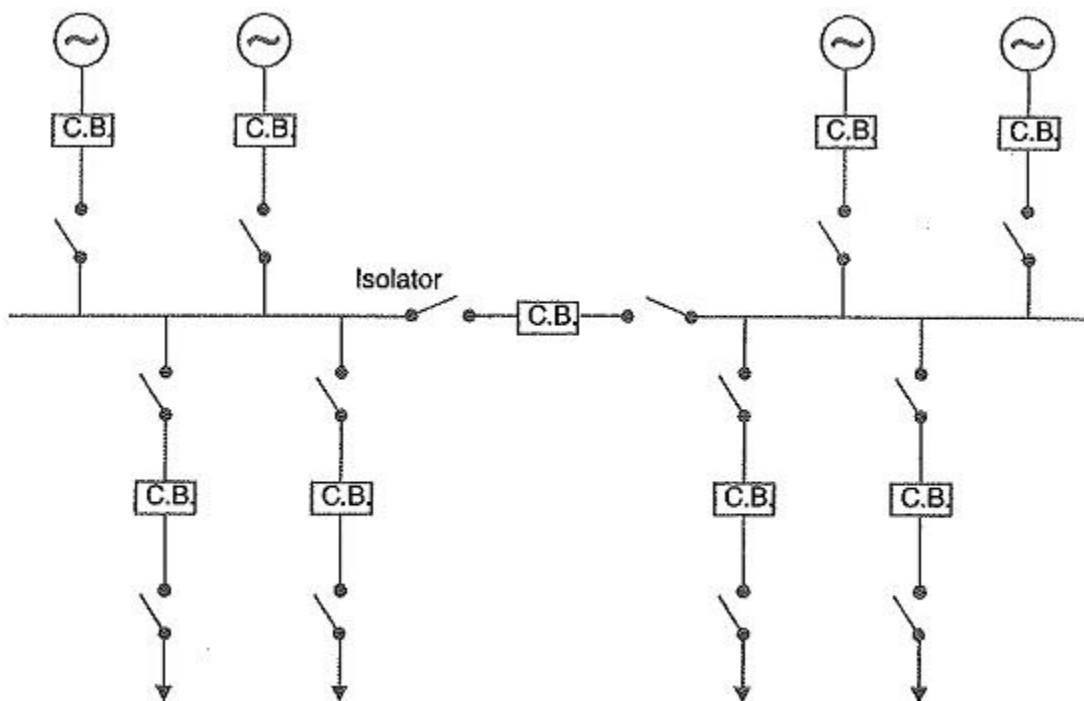

Fig. 16.3

Advantage of single Bus-bar Arrangement with Bus Sectionalization

- ✓ The following are the advantages of sectionalized bus bar.
- ✓ The faulty section is removed without affecting the continuity of the supply.
- ✓ The maintenance of the individual section can be done without disturbing the system supply.
- ✓ The system has a current limiting reactor which decreases the occurrence of the fault.

Disadvantages of Single Bus-Bar Arrangement with Sectionalization

- ✓ The system uses the additional circuit breaker and isolator which increases the cost of the system.

Duplicate bus-bar system: In large stations, it is important that breakdowns and maintenance should interfere as little as possible with continuity of supply. In order to achieve this objective, duplicate Bus Bar Arrangement in Power Station is used in important stations. Such a system consists of two bus-bars, a “main bus-bar” and a “spare” bus-bar (see Fig. 16.4). Each generator and feeder may be connected to either bus-bar with the help of bus coupler which consists of a circuit breaker and isolators.

In the scheme shown Main in Fig. 16.4, service is interrupted during switch over from one bus to another.

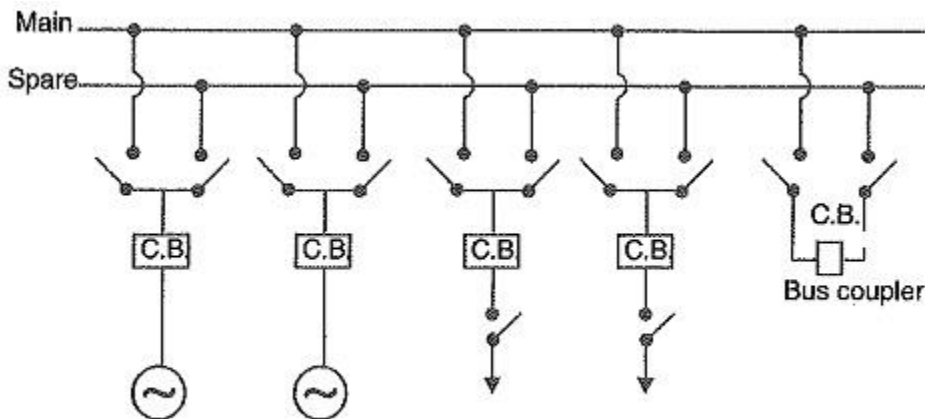

Fig. 16.4

Advantages

- ✓ If repair and maintenance it to be carried on the main bus, the supply need not be interrupted as the entire load can be transferred to the spare bus.
- ✓ The testing of feeder circuit breakers can be done by putting them on spare bus-bar, thus keeping the main bus-bar undisturbed.
- ✓ If a fault occurs on the bus-bar, the continuity of supply to the circuit can be maintained by transferring it to the other Bus Bar Arrangement in Power Station.

Switchgear Accommodation:

The main components of switchgear are circuit breakers, switches, bus-bars, instruments and instrument transformers. It is necessary to house the switchgear in power stations and sub-stations in such a way so as to safeguard personnel during operation and maintenance and to ensure that the effects of fault on any section of the gear are confined to a limited region. Depending upon the voltage to be handled, switchgear may be broadly classified into

(i) Outdoor type

(ii) Indoor type.

(i) Outdoor type: For voltages beyond 66 kV, switchgear equipment is installed outdoor. It is because for such voltages, the clearances between conductors and the space required for switches, circuit breakers,

transformers and others equipment become so great that it is not economical to install all such equipment indoor.

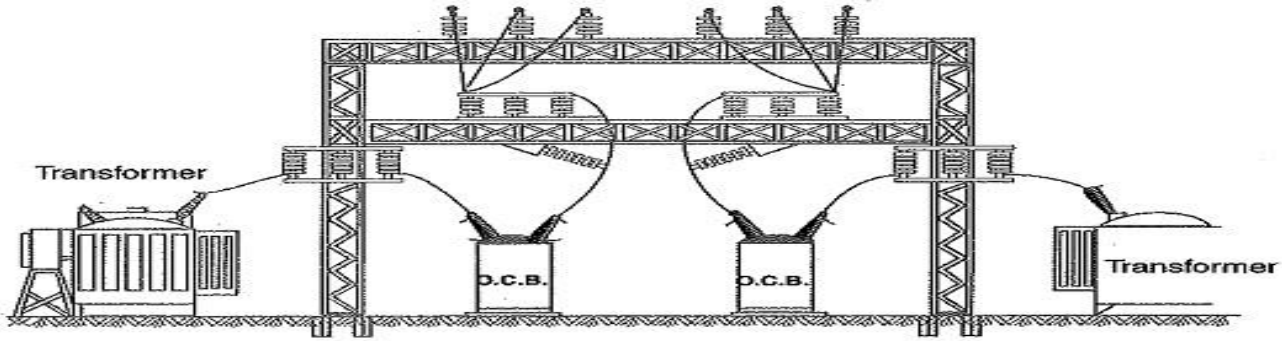

Fig. 16.5

Fig. 16.5 shows a typical outdoor sub-station with switchgear equipment. The circuit breakers, isolators, transformers and bus-bars occupy considerable space on account of large electrical clear-ance associated with high voltages.

(ii) **Indoor type:** For voltages below 66 kV, switchgear is generally installed indoor because of economic considerations. The indoor switchgear is generally of metal-clad type. In this type of construction, all live parts are completely enclosed in an earthed metal casing. The primary object of this practice is the definite localization and restriction of any fault to its place of origin.

Short Circuit:

Whenever a fault occurs on a network such that a large current flows in one or more phases, a short circuit is said to have occurred.

Faults in a power system:

When two or more conductors that normally operate with a potential difference come in contact with each other, fault may be caused by sudden failure of a piece of equipment or short circuit to overhead line or by insulation failure resulting from lighting surge.

There are mainly two types of faults in the electrical power system. **Those are symmetrical and unsymmetrical faults.**

1. Symmetrical faults

- ✓ These are very severe faults and occur infrequently in the power systems. These are also called as balanced faults and are of two types namely line to line to line to ground (L-L-L-G) and line to line to line (L-L-L).
- ✓ Only 2-5 percent of system faults are symmetrical faults. If these faults occur, system remains balanced but results in severe damage to the electrical power system equipments.

2. Unsymmetrical faults

- ✓ These are very common and less severe than symmetrical faults. There are mainly three types namely line to ground (L-G), line to line (L-L) and double line to ground (LL-G) faults.
- ✓ Line to ground fault (L-G) is most common fault and 65-70 percent of faults are of this type.
- ✓ It causes the conductor to make contact with earth or ground. 15 to 20 percent of faults are double line to ground and causes the two conductors to make contact with ground.
- ✓ Line to line faults occur when two conductors make contact with each other mainly while swinging of lines due to winds and 5- 10 percent of the faults are of this type.

.....

FAULT CALCULATION

Symmetrical faults on 3-phase system:

That fault on the power system which gives rise to symmetrical fault currents (i.e. equal fault currents in the lines with 120° displacement) is called a symmetrical fault.

The symmetrical fault occurs when all the three conductors of a 3-phase line are brought together simultaneously into a short-circuit condition as shown in Fig. 17.1. This type of fault gives rise to symmetrical currents i.e. equal fault currents with 120° displacement. Thus referring to Fig. 17.1, fault currents I_R , I_Y and I_B will be equal in magnitude with 120° displacement among them. Because of balanced nature of fault, only one phase need be considered in calculations since condition in the other two phases will also be similar.

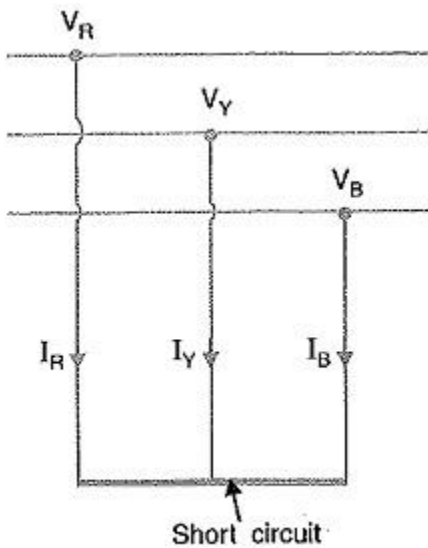

Fig. 17.1

The following points may be particularly noted:

1. The symmetrical fault rarely occurs in practice as majority of the faults are of unsymmetrical nature. However, symmetrical fault calculations are being discussed in this chapter to enable the reader to understand the problems that short circuit conditions present to the power system.
2. The symmetrical fault is the most severe and imposes more heavy duty on the circuit breaker.

Limitation of Fault Current:

When a short circuit occurs at any point in a system, the short-circuit current is limited by the impedance of the system up to the point of fault. Thus referring to Fig. 17.2, if a Symmetrical Faults on 3 Phase System occurs on the feeder at point F, then the short circuit current from the generating station will have a value limited by the impedance of generator and transformer and the impedance of the line between the generator and the point of Symmetrical Faults on 3 Phase System.

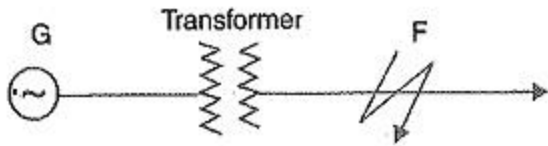

Fig. 17.2

In many situations, the impedances limiting the Symmetrical Faults on 3 Phase System current are largely reactive, such as transformers, reactors and generators. Cables and lines are mostly resistive, but where the total reactance in calculations exceeds 3 times the resistance, the latter is usually neglected. The error introduced by this assumption will not exceed 5%.

Percentage Reactance:

The Percentage Reactance in Power System of generators, transformers, reactors etc. is usually expressed in percentage reactance to permit rapid short circuit calculations.

The percentage reactance of a circuit is defined as under:

It is the percentage of the total phase-voltage dropped in the circuit when full-load current is flowing.

$$\%X = \frac{IX}{V} \times 100 \dots\dots\dots (i)$$

Where I=full load current

V= phase voltage

X= reactance in ohms per phase

Alternatively, percentage reactance (%X) can also be expressed in terms of kVA and kV as under

$$\%X = \frac{(kVA)X}{10(kV)^2} \dots\dots\dots (ii)$$

Where X is the reactance in ohms.

If X is the only reactance element in the circuit, then short-circuit current is given by;

$$I_{sc} = \frac{V}{X}$$

$$= I \left(\frac{100}{\%X} \right) \quad \text{[putting the value of X from exp.(i)]}$$

I.e. short circuit current is obtained by multiplying the full-load current by 100 / % X.

Percentage Reactance and Base KVA:

It is clear from exp. (ii) above that percentage reactance of equipment depends upon its kVA rating. Generally, the various equipments used in the power system have different kVA ratings.

Therefore, it is necessary to find the Percentage Reactance in Power System of all the elements on a common kVA rating. This common kVA rating is known as **base kVA**. The value of this base kVA is quite unimportant and may be:

- equal to that of the largest plant
- equal to the total plant capacity
- any arbitrary value

The conversion can be effected by using the following relation:

$$\%age \text{ reactance at base kVA} = \frac{\text{Base kVA}}{\text{Rated kVA}} \times \%age \text{ reactance at rated kVA}$$

Short Circuit kVA:

Although the potential at the point of fault is zero, it is a normal practice to express the short-circuit current in terms of Short Circuit kVA based on the normal system voltage at the point of fault.

The product of normal system voltage and short-circuit current at the point of fault expressed in kVA is known as Short Circuit kVA.

Let

V = normal phase voltage in volts

I = full-load current in amperes at base kVA

%X = percentage reactance of the system on base kVA up to the fault point

Short-circuit current, $I_{sc} = I \left(\frac{100}{\%X} \right)$

Short-circuit kVA for 3-phase circuit

$$\begin{aligned} &= \frac{3VI_{sc}}{1000} \\ &= \frac{3VI}{1000} \times \frac{100}{\%X} \\ &= \text{Base kVA} \times \frac{100}{\%X} \end{aligned}$$

i.e. Short Circuit kVA is obtained by multiplying the base kVA by 100/% X.

Reactor control of short circuit currents:

- ✓ Short circuit current is reduced by an increase in the reactance of the system. Short circuit current depends on the generating capacity, voltage at the fault point and the total reactance between the generating point and the fault location.
- ✓ Breaking capacity of the circuit breaker depends on the magnitude of the fault current. If the fault current is beyond the designed limit of the breaking capacity of the breaker, the fault cannot be extinguished.
- ✓ Therefore in large interconnected power system large number of generators and motors feed the fault on occurrence of the fault.

- ✓ Therefore at times the magnitude of the short circuit current exceeds the breaking capacity of the breaker.
- ✓ Therefore it is necessary to limit the fault current by some means. By including a reactor or few reactors at some strategic locations, short circuit currents at different points can be reduced.

Advantages:

- ✓ Protective reactors are used to reduce the flow of short circuit current at the fault point so as to protect the apparatus from excessive mechanical stresses and from overheating and thus protect the system as a whole
- ✓ Protective systems are used to reduce the voltage disturbances caused by the short circuits
- ✓ They also localize the fault by limiting the current that flow in to the fault from other healthy feeders or parts of the system thereby avoiding the fault by spreading
- ✓ It helps to reduce the duty imposed on the switching equipment during fault conditions.

Disadvantages:

- ✓ Total percentage reactance of the system increases thereby causing increase in reactive voltage drop and decrease in power factor due to increased angle of lag. Thus regulation of the system becomes poor.

Location of reactors

Short circuit current limiting Location of Reactors in Power System may be con-nected

1. in series with each generator
2. in series with each feeder and
3. in bus-bars.

1. Generator Reactors:

When the reactors are connected in series with each generator, they are known as generator reactors (see Fig. 17.4). In this case, the reactor may be considered as a part of leak-age reactance of the generator; hence its effect is to protect the generator in the case of any short-circuit beyond the reactors.

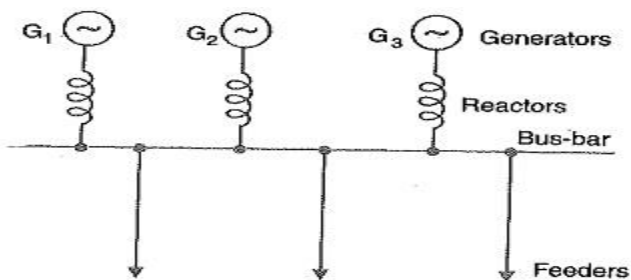

Fig. 17.4

Disadvantages

- ✓ There is a constant voltage drop and power loss in the Location of Reactors in Power System even during normal operation.
- ✓ If a bus-bar or feeder fault occurs close to the bus-bar, the voltage at the bus-bar will be reduced to a low value, thereby causing the generators to fall out of step.
- ✓ If a fault occurs on any feeder, the continuity of supply to other is likely to be affected.

2. Feeder Reactors:

When the reactors are connected in series with each feeder, they are known as feeder reactors (see Fig. 17.5). Since most of the short-circuits occur on feeders, a large number of reactors are used for such circuits. Two principal advantages are claimed for feeder Location of Reactors in Power System. Firstly, if a fault occurs on any feeder, the voltage drop in its reactor will not affect the bus-bars voltage so that there is a little tendency for the generator to lose synchronism. Secondly, the fault on a feeder will not affect other feeders and consequently the effects of fault are localized.

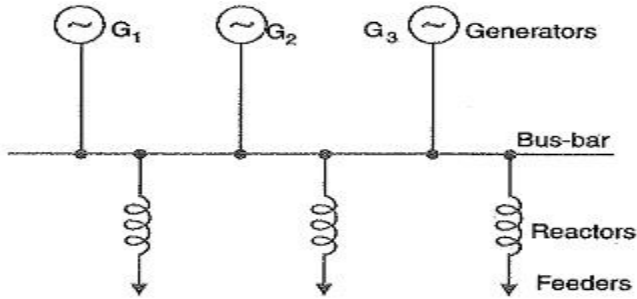

Fig. 17.5

Disadvantages

- ✓ There is a constant power loss and voltage drop in the reactors even during normal operation.
- ✓ If a short-circuit occurs at the bus-bars, no protection is provided to the generators.
- ✓ If the number of generators is increased, the size of feeder reactors will have to be increased to keep the short-circuit currents within the ratings of the feeder circuit breakers.

3. Bus-bar reactors:

The above two methods of locating reactors suffer from the disadvantage that there is considerable voltage drop and power loss in the Location of Reactors in Power System even during normal operation. This disadvantage can be overcome by locating the reactors in the bus-bars. There are two methods for this purpose, namely ; Ring system and Tie-Bar system.

(i) Ring system:

In this system, bus-bar is divided into sections and these sections are connected through reactors as shown in Fig. 17.6. Generally, one feeder is fed from one generator only. Under normal operating conditions, each generator will supply its own section of the load and very little power will be fed by other generators. This result in low power loss and voltage drop in the reactors.

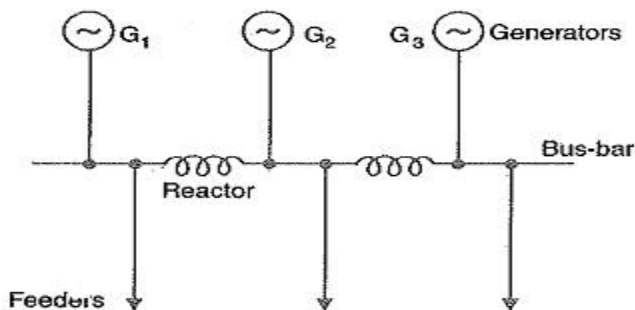

Fig. 17.6

(ii) Tie-Bar system:

Fig. 17.7 shows the tie-bar system. Comparing the ring system with tie-bar system, it is clear that in the tie-bar system, there are effectively two reactors in series between sections so that Location of Reactors in Power System must have approximately half the reactance of those used in a comparable ring system. Another advantage of tie-bar system is that additional generators may be connected to the system without requiring changes in the existing reactors. However, this system has the disadvantage that it requires an additional bus-bar i.e. the tie-bar.

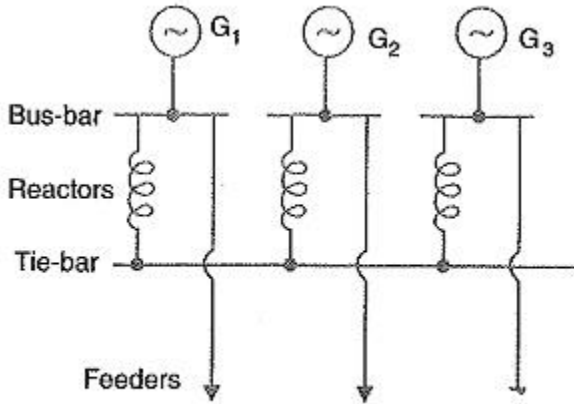

Fig. 17.7

Steps for Symmetrical Fault Calculations:

It has already been discussed that 3-phase short-circuit faults result in symmetrical fault currents i.e. fault currents in the three phases are equal in magnitude but displaced 120° electrical from one another. Therefore, problems involving such faults can be solved by considering one phase only as the same conditions prevail in the other two phases. The procedure for the solution of such faults involves the following steps:

- ✓ Draw a single line diagram of the complete network indicating the rating, voltage and per-centage reactance of each element of the network.
- ✓ Choose a numerically convenient value of base kVA and convert all percentage reactances to this base value.
- ✓ Corresponding to the single line diagram of the network, draw the reactance diagram showing one phase of the system and the neutral. Indicate the % reactance on the base kVA in the reactance diagram. The transformer in the system should be represented by a reactance in series.
- ✓ Find the total % reactance of the network up to the point of fault. Let it be X%.
- ✓ Find the full-load current corresponding to the selected base kVA and the normal system voltage at the fault point. Let it be I.
- ✓ Then various short-circuit calculations are :

$$\text{Short-circuit current, } I_{sc} = I \times \frac{100}{\%X}$$

$$\text{Short-circuit kVA} = \text{Base kVA} \times \frac{100}{\%X}$$

UNIT-3

FUSES

A fuse is a short piece of metal, inserted in the circuit, which melts when excessive current flows through it and thus breaks the circuit.

Advantages

- ✓ It is the cheapest form of protection available.
- ✓ It requires no maintenance.
- ✓ Its operation is inherently completely automatic unlike a circuit breaker which requires an elaborate equipment for automatic action.
- ✓ It can break heavy short-circuit currents without noise or smoke.
- ✓ The smaller sizes of fuse element impose a current limiting effect under short-circuit conditions.
- ✓ The inverse time-current characteristic of a Fuses Definition makes it suitable for over current protection.
- ✓ The minimum time of operation can be made much shorter than with the circuit breakers.

Disadvantages

- ✓ Considerable time is lost in rewiring or replacing a fuse after operation.
- ✓ On heavy short-circuits, discrimination between fuses in series cannot be obtained unless there is sufficient difference in the sizes of the Fuses Definition concerned.
- ✓ The current-time characteristic of a fuse cannot always be co-related with that of the protected apparatus.

Characteristics of Fuse Element:

The function of a fuse is to carry the normal current without overheating but when the current exceeds its normal value; it rapidly heats up to melting point and disconnects the circuit protected by it. In order that it may perform this function satisfactorily, the fuse element should have the following desirable

characteristics:

- ✓ Low melting point e.g., tin, lead.
- ✓ High conductivity e.g., silver, copper.
- ✓ free from deterioration due to oxidation e.g., silver
- ✓ Low cost e.g., lead, tin, copper.

Fuse Element Materials:

The most commonly used materials for fuse element are lead, tin, copper, zinc and silver. For small currents up to 10 A, tin or all alloy of lead and tin (lead 37%, tin 63%) is used for making the fuse element. For larger currents, copper or silver is employed. It is a usual practice to tin the copper to protect it from

oxidation. Zinc (in strip form only) is good if a Fuses Definition with considerable time-lag is required i.e., one which does not melt very quickly with a small overload.

The present trend is to use silver despite its high cost due to the following reasons :

- ✓ It is comparatively free from oxidation.
- ✓ It does not deteriorate when used in dry air.
- ✓ The coefficient of expansion of silver is so small that no critical fatigue occurs. Therefore, the fuse element can carry the rated current continuously for a long time.
- ✓ The conductivity of silver is very high. Therefore, for a given rating of fuse element.
- ✓ Due to comparatively low specific heat, silver fusible elements can be raised from normal temperature to vaporization quicker than other fusible elements. Consequently, operation becomes very much faster at higher
- ✓ Silver vaporizes at a temperature much lower than the one at which its vapour will readily
Therefore, when an arc is formed through the vaporized portion of the element, the arc path has high resistance. As a result, short-circuit current is quickly interrupted.

Important Terms in Fuses

The following terms are much used in the analysis of fuses :

Current rating of fuse element: It is the current which the fuse element can normally carry without overheating or It depends upon the temperature rise of the contacts of the fuse holder, fuse material and the surroundings of the Fuses Definition.

Fusing current: It is the minimum current at which the fuse element melts and thus disconnects the circuit protected by it. Obviously, its value will be more than the current rating of the fuse element.

For a round wire, the approximate relationship between fusing current I and diameter d of the wire is

$$I=kd^{3/2}$$

The fusing current depends upon the various factors such as:

1. Material of fuse element
2. Length — the smaller the length, the greater the current because a short fuse can easily conduct away all the heat
3. Diameter
4. Size and location of terminals
5. Previous history
6. Type of enclosure used.

Fusing factor:

It is the ratio of minimum fusing current to the current rating of the fuse element i.e.

$$\text{Fusing factor} = \frac{\text{Minimum fusing current}}{\text{Current rating of fuse}}$$

Its value is always more than one. The smaller the fusing factor, the greater is the difficulty in avoiding deterioration due to overheating and oxidation at rated carrying current. For a semi-en-closed or rewirable Fuses Definition which employs copper wire as the fuse element, the fusing factor is usually 2. Lower values of fusing factor can be employed for enclosed type cartridge fuses using silver or bimetallic elements.

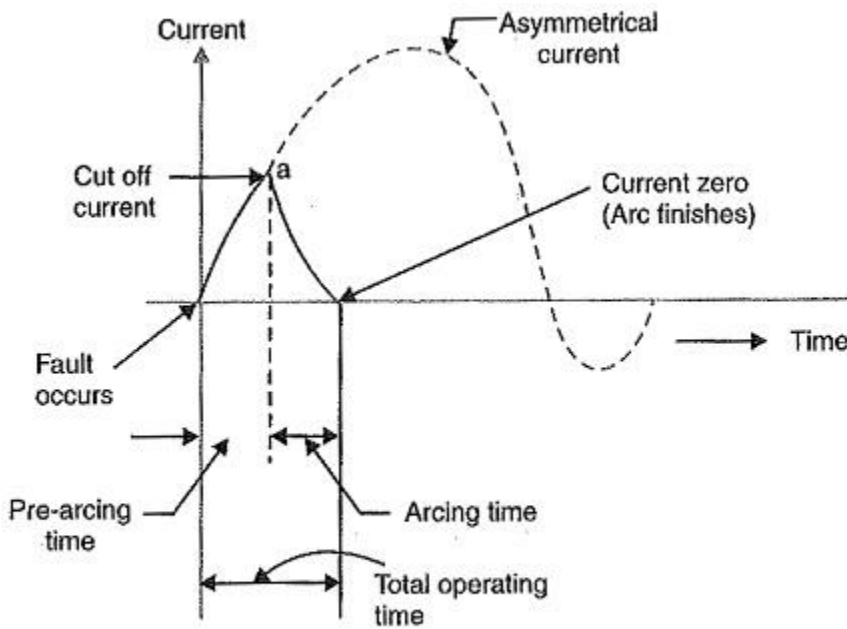

Fig. 20.2

Prospective Current:

Fig. 20.2 shows how a.c. current is cut off by a fuse. The fault current would normally have a very large first loop, but it actually generates sufficient energy to melt the fuseable element well before the peak of this first loop is reached. The R.M.S. value of the first loop of fault current is known as prospective current. *Therefore, prospective current can be defined as under:*

It is the R.M.S. value of the first loop of the fault current obtained if the fuse is replaced by an ordinary conductor of negligible resistance.

Cut-off current:

It is the maximum value of fault current actually reached before the fuse melts.

On the occurrence of a fault, the fault current has a very large first loop due to a fair degree of asymmetry. The heat generated is sufficient to melt the fuse element well before the peak of first loop is reached (point 'a' in Fig. 20.2). The current corresponding to point 'a' is the cut off current. The cut off value depends upon

- ✓ current rating of fuse
- ✓ value of prospective current
- ✓ asymmetry of short-circuit current

Pre-arcing time:

It is the time between the commencement of fault and the instant when cut off occurs.

When a fault occurs, the fault current rises rapidly and generates heat in the fuse element. As the fault current reaches the cut off value, the fuse element melts and an arc is initiated. *The time from the start of the fault to the instant the arc is initiated is known as pre-arcing time.* The pre-arcing time is generally small: a typical value being 0.001 second

Arcing time:

This is the time between the end of pre-arcing time and the instant when the arc is extinguished.

Total operating time:

It is the sum of pre-arcing and arcing times.

Breaking capacity:

It is the R.M.S. value of a.c. component of maximum prospective current that a fuse can deal with at rated service voltage.

Types of Fuses

Types of Fuses may be classified into:

1. Low voltages fuses
2. High voltage fuses

Low Voltage Fuses:

Low voltage fuses can be subdivided into two classes viz.,

1. Semi-enclosed rewirable fuse
2. High rupturing capacity (H.R.C.) cartridge fuse.

1. Semi-enclosed Rewirable fuse:

- ✓ Rewirable fuse (also known as kit-kat type) is used where low values of fault current are to be interrupted. It consists of (i) a base and (ii) a fuse carrier.

- ✓ The base is of porcelain and carries the fixed contacts to which the incoming and outgoing phase wires are connected.
- ✓ The fuse carrier is also of porcelain and holds the Types of Fuses element (tinned copper wire) between its terminals. The fuse carrier can be inserted in Of taken out of the base when desired.
- ✓ When a fault occurs, the fuse element is blown out and the circuit is interrupted. The fuse carrier is taken out and the blown out fuse element is replaced by the new one.
- ✓ The fuse carrier is then re-inserted in the base to restore the supply. This type of fuse has two advantages. Firstly, the detach-able fuse carrier permits the replacement of Types of Fuses element without any danger of coming in contact with live parts. Secondly, the cost of replacement is negligible.

Disadvantages

- ✓ There is a possibility of renewal by the fuse wire of wrong size or by improper material.
- ✓ This type of fuse has a low-breaking capacity and hence cannot be used in circuits of high fault level.
- ✓ The fuse element is subjected to deterioration due, to oxidation through the continuous heating up of the element.
- ✓ The protective capacity of such a Types of Fuses is uncertain as it is affected by the ambient conditions.
- ✓ Accurate calibration of the fuse wire is not possible because fusing current very much de-pends upon the length of the fuse element.

Semi-enclosed rewirable fuses are made up to 500 A rated current, but their breaking capacity is low e.g., on 400 V service, the breaking capacity is about 4000 A. Therefore, the use of this Types of Fuses is limited to domestic and lighting loads.

2. High-Rupturing capacity (H.R.C.) cartridge fuse:

- ✓ The primary objection of low and uncertain breaking capacity of semi-enclosed rewirable fuses is overcome in H.R.C. cartridge fuse.

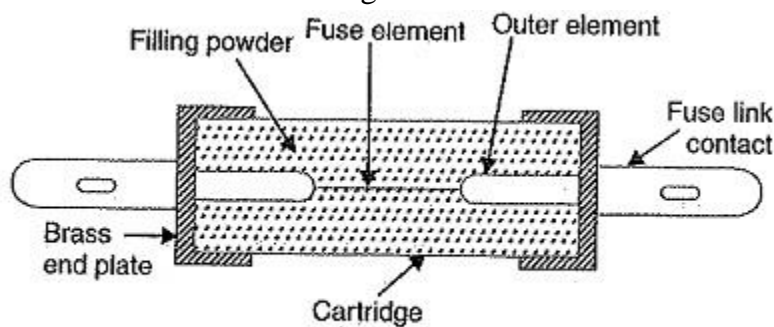

Fig. 20.3

- ✓ Fig. 20.3 shows the essential parts of a typical H.R.C. cartridge fuse. It consists of a heat resisting ceramic body having metal end-caps to which is welded silver current-carrying element.

- ✓ The space within the body surrounding the element is completely packed with a filling powder. The filling material may be chalk, plaster of paris, quartz or marble dust and acts as an arc quenching and cooling medium.
- ✓ Under normal load conditions, the fuse element is at a temperature below its melting point.
- ✓ Therefore, it carries the normal current without overheating. When a fault occurs, the current increases and the fuse element melt before the fault current reaches its first peak.
- ✓ The heat produced in the process vaporizes the melted silver element. The chemical reaction between the silver vapour and the filling powder results in the formation of a high resistance substance which helps in quenching the arc.

Advantages

- They are capable of clearing high as well as lo
- They do not deteriorate with age.
- They have high speed of operation.
- They provide reliable discrimination.
- They require no maintenance.
- They are cheaper than other circuit interrupting devices of equal breaking capacity.
- They permit consistent performance.

Disadvantages

- They have to be replaced after each operation.
- Heat produced by the arc may affect the associated switches.

3. H.R.C. fuse with tripping device:

- ✓ Sometime, H.R.C. cartridge fuse is provided with a tripping device. When the fuse blows out under fault conditions, the tripping device causes the circuit breaker to operate.
- ✓ Fig. 20.4 shows the essential parts of a H.R.C. fuse within tripping device. The body of the fuse is of ceramic material with a metallic cap rigidly fixed at each end.
- ✓ These are connected by a number of silver fuse elements. At one end is a plunger which under fault conditions hits the tripping mechanism of the circuit breaker and causes it to operate.
- ✓ The plunger is electrically connected through a fusible link, chemical charge and a tungsten shunt to the other end of the cap as shown.

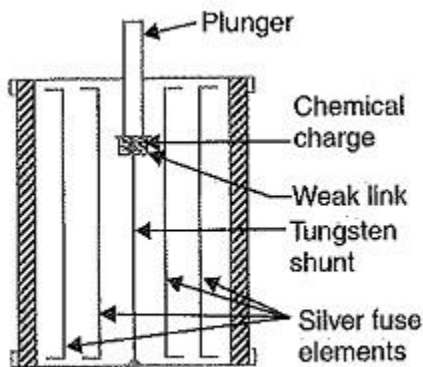

Fig. 20.4

- ✓ When a fault occurs, the silver fuse elements are the first to be blown out and then current is transferred to the tungsten wire.

- ✓ The weak link in series with the tungsten wire gets fused and causes the chemical charge to be detonated. This forces the plunger outward to operate the circuit breaker.
- ✓ The travel of the plunger is so set that it is not ejected from the fuse body under fault conditions.

Advantages:

- ✓ In case of a single phase fault on a three-phase system, the plunger operates the tripping mechanism of circuit breaker to open all the three phases and thus prevents “single phasing”.
- ✓ The effects of full short circuit Gwent need not be considered in the choice of circuit breaker. This permits the use of a relatively inexpensive circuit breaker.
- ✓ The fuse-tripped circuit breaker is generally capable of dealing with fairly small fault currents itself. This avoids the necessity for replacing the fuse except after highest currents for which it is intended.

Low voltage H.R.C. fuses may be built with a breaking capacity of 16,000 A to 30,000 A at 440V. They are extensively used on low-voltage distribution system against over-load and short-circuit conditions.

High Voltage Fuses:

The low-voltage fuses discussed so far have low normal current rating and breaking capacity. Therefore, they cannot be successfully used on modern high voltage circuits. Intensive research by the manufacturers and supply engineers has led to the development of high voltage fuses. Some of the high voltage fuses are :

1. Cartridge type:

- ✓ This is similar in general construction to the low voltage cartridge type except that special design features are incorporated.
- ✓ Some designs employ fuse elements wound in the form of a helix so as to avoid corona effects at higher voltages. On some designs, there are two fuse elements in parallel; one of low resistance (silver wire) and the other of high resistance (tungsten wire).
- ✓ Under normal load conditions, the low resistance element carries the normal current. When a fault occurs, the low-resistance element is blown out and the high resistance element reduces the short-circuit current and finally breaks the circuit.



- ✓ High voltage cartridge fuses are used upto 33 kV with breaking ca-pacity of about 8700 A at that voltage. Rating of the order of 200 A at 6.6 kV and 11 kV and 50 A at 33 kV are also available.

2. Liquid type:

- ✓ These Types of Fuses are filled with carbon tetrachloride and have the widest range of application to H.V. systems. They may be used for circuits up to about 100 A rated current on systems up to 132 kV and may have breaking capacities of the order of 6100 A.

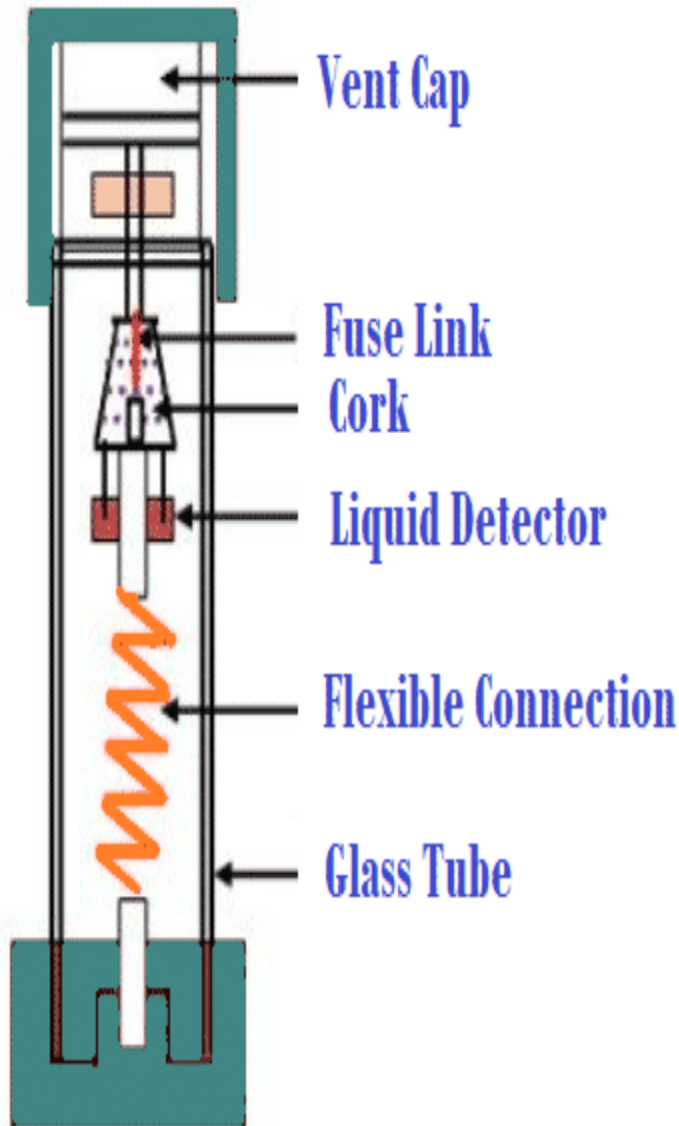

- ✓ Figure shows the essential parts of the liquid fuse.
- ✓ It consists of a glass tube filled with carbon tetrachloride solution and sealed at both ends with brass caps.
- ✓ The fuse wire is sealed at one end of the tube and the other end of the wire is held by a strong phosphor bronze spiral spring fixed at the other end of the glass tube

- ✓ . When the current exceeds the prescribed limit, the fuse wire is blown out. As the fuse melts, the spring retracts part of it through a baffle (or liquid director) and draws it well into the liquid.
- ✓ The small quantity of gas generated at the point of fusion forces some part of liquid into the passage through baffle and there it effectively extinguishes the arc.

3. Metal clad fuses:

Metal clad oil-immersed fuses have been developed with the object of providing a substitute for the oil circuit breaker. Such Types of Fuses can be used for very high voltage circuits and operate most satisfactorily under short-circuit conditions approaching their rated capacity.

Current Carrying Capacity of Fuse Element:

The current carrying capacity of a fuse element mainly depends on the metal used and the cross-sectional area but is affected also by the length, the state of surface and the surroundings of the fuse. When the fuse element attains steady temperature,

Heat produced per sec = Heat lost per second by convection, radiation and conduction

$$I^2 R = \text{Constant} \times \text{Effective surface area}$$

$$I^2 \left(\rho \frac{l}{a} \right) = \text{constant} \times d \times l$$

d = diameter of fuse element

l = length of fuse element

$$I^2 \frac{\rho l}{(\pi/4) d^2} = \text{constant} \times d \times l$$

$$I^2 = \text{constant} \times d^3$$

$$I^2 \propto d^3$$

...(i)

Expression (i) is known as ordinary fuse law.

Difference between a Fuse and Circuit Breaker:

S. No.	Particular	Fuse	Circuit breaker
1.	<i>Function</i>	It performs both detection and interruption functions.	It performs interruption function only. The detection of fault is made by relay system.
2.	<i>Operation</i>	Inherently completely automatic.	Requires elaborate equipment (<i>i.e.</i> relays) for automatic action.
3.	<i>Breaking capacity</i>	Small	Very large
4.	<i>Operating time</i>	Very small (0.002 sec or so)	Comparatively large (0.1 to 0.2 sec)
5.	<i>Replacement</i>	Requires replacement after every operation.	No replacement after operation.

UNIT-4

CIRCUIT BREAKERS

Definition:

A circuit breaker is a switching device that interrupts the abnormal or fault current. It is a mechanical device that disturbs the flow of high magnitude (fault) current and in additions performs the function of a switch. The circuit breaker is mainly designed for closing or opening of an electrical circuit, thus protects the electrical system from damage.

Working Principle of Circuit Breaker:

- ✓ Circuit breaker essentially consists of fixed and moving contacts. These contacts are touching each other and carrying the current under normal conditions when the circuit is closed.
- ✓ When the circuit breaker is closed, the current carrying contacts, called the electrodes, engaged each other under the pressure of a spring.
- ✓ During the normal operating condition, the arms of the circuit breaker can be opened or closed for a switching and maintenance of the system. To open the circuit breaker, only a pressure is required to be applied to a trigger.

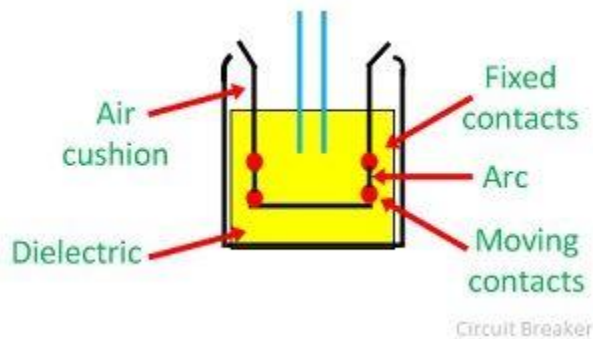

- ✓ Whenever a fault occurs on any part of the system, the trip coil of the breaker gets energized and the moving contacts are getting apart from each other by some mechanism, thus opening the circuit.

Arc Phenomenon:

- ✓ When a short-circuit occurs, a heavy current flows through the contacts of the 'circuit breaker, before they are opened by the protective system.
- ✓ At the instant when the contacts begin to separate, the contact area decreases rapidly and large fault current causes increased current density and hence rise in temperature.
- ✓ The heat produced in the medium between contacts (usually the medium is oil or air) is sufficient to ionize the air or vaporized and ionize the oil.
- ✓ The ionized air or vapor acts as conductor and an arc is struck between the contacts. The p.d. between the contacts is quite small and is just sufficient to maintain the arc.
- ✓ The arc provides a low resistance path and consequently the current in the circuit remains uninterrupted so long as the arc persists.

- ✓ During the arcing period, the current flowing between the contacts depends upon the arc resistance. The greater the arc resistance, the smaller the current that flows between the contacts.

The arc resistance depends upon the following factors:

Degree of ionization – The arc resistance increases with the decrease in the number of ionized particles between the contacts.

Length of the arc – The arc resistance increases with the length of the arc i.e., separation of contacts.

Cross-section of arc – The arc resistance increases with the decrease in area of X-section of the arc.

Principles of Arc Extinction:

Before discussing the methods of arc extinction, it is necessary to examine the factors responsible for the maintenance of arc between the contacts. These are:

1. p.d. between the contacts
2. ionized particles between contacts

Taking these in turn,

1. When the contacts have a small separation, the p.d. between them is sufficient to maintain the arc. One way to extinguish the arc is to separate the contacts to such a distance that p.d. becomes inadequate to maintain the arc. However, this method is impracticable in high voltage system where a separation of many metres may be required.
2. The ionized particles between the contacts tend to maintain the arc. If the arc path is deionized, the arc extinction will be facilitated. This may be achieved by cooling the arc or by bodily removing the ionized particles from the space between the contacts.

Methods of Arc Extinction:

There are two methods of extinguishing the arc in Circuit Breakers Definition via

1. High resistance method.
2. Low resistance or current zero method

1. High resistance method:

In this method, arc resistance is made to increase with time so that current is reduced to a value insufficient to maintain the arc. Consequently, the current is interrupted or the arc is extinguished. The principal disadvantage of this method is that enormous energy is dissipated in the arc. Therefore, it is employed only in D.C. circuit breakers and low-capacity a.c. Circuit Breakers Definition.

The resistance of the arc may be increased by:

Lengthening the arc:

The resistance of the arc is directly proportional to its length. The length of the arc can be increased by increasing the gap between contacts.

Cooling the arc:

Cooling helps in the deionization of the medium between the contacts. This increases the arc resistance. Efficient cooling may be obtained by a gas blast directed along the arc.

Reducing X-section of the arc:

If the area of X-section of the arc is reduced, the voltage necessary to maintain the arc is increased. In other words, the resistance of the arc path is The cross-section of the arc can be reduced by letting the arc pass through a narrow opening or by having smaller area of contacts.

Splitting the arc:

The resistance of the arc can be increased by splitting the arc into a number of smaller arcs in series. Each one of these arcs experiences the effect of lengthening and cooling. The arc may be split by introducing some conducting plates between the

2. Low resistance or Current zero method:

- ✓ This method is employed for arc extinction in a.c. circuits only. In this method, arc resistance is kept low until current is zero where the arc extinguishes naturally and is prevented from restriking inspite of the rising voltage across the contacts. All modern high power a.c. circuit breakers employ this method for arc extinction.
- ✓ In an a.c. system, current drops to zero after every half-cycle. At every current zero, the arc extinguishes for a brief moment.
- ✓ Now the medium between the contacts contains ions and electrons so that it has small dielectric strength and can be easily broken down by the rising contact voltage known as restriking voltage. If such a breakdown does occur, the arc will persist for another half-cycle.
- ✓ If immediately after current zero, the dielectric strength of the medium between contacts is built up more rapidly than the voltage across the contacts, the arc fails to restrike and the current will be interrupted. The rapid increase of dielectric strength of the medium near current zero can be achieved by:
 1. Causing the ionized particles in the space between contacts to recombine into neutral molecules.
 2. sweeping the ionized particles away and replacing them by un-ionized particles

Lengthening of the Gap:

The dielectric strength of the medium is proportional to the length of the gap between contacts. Therefore, by opening the contacts rapidly, higher dielectric strength of the medium can be achieved.

High Pressure:

If the pressure in the vicinity of the arc is increased, the density of the particles constituting the discharge also increases. The increased density of particles causes higher rate of de-ionization and consequently the dielectric strength of the medium between contacts is increased.

Cooling:

Natural combination of ionized particles takes place more rapidly if they are allowed to cool. Therefore, dielectric strength of the medium between the contacts can be increased by cooling the arc.

Blast effect:

If the ionized particles between the contacts are swept away and replaced by un-ionised particles, the dielectric strength of the medium can be increased considerably. This may be achieved by a gas blast directed along the discharge or by forcing oil into the contact space.

Important Points to be Remember:

1. Arc voltage:

It is the voltage that appears across the contacts of the circuit breaker during the arcing period.

2. Restriking Voltage:

It is the transient voltage that appears across the contacts at or near current zero during arcing period.

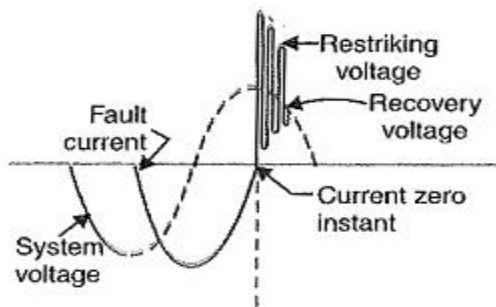

Fig. 19.1

3. Recovery voltage:

It is the normal frequency (50 Hz) R.M.S. voltage that appears across the contacts of the circuit breaker after final arc extinction. It is approximately equal to the system voltage.

Classification of circuit Breakers

1. Air Blast Circuit Breakers
2. Oil Circuit Breakers
3. Sulfur hexafluoride (SF₆) Circuit Breakers
4. Vacuum Circuit Breakers

Air Blast Circuit Breakers

The second 'air' based circuit breakers are air blast circuit breakers. In this type, a high-pressure air-blast is used as arc extinguishing medium. In case of a fault, the air-blast, controlled by a blast valve, will open the contacts and also cools the arc.

There are three types of air blast circuit breakers based on the direction of the air-blast in relation to the arc. They are:

1. Axial Blast Type
2. Cross Blast Type
3. Radial Blast Type

In axial-blast circuit breakers, the air-blast flows in the same direction as the arc. The high-pressure air-blast will push the moving contact away, opening the circuit and also pushes the arc along with it.

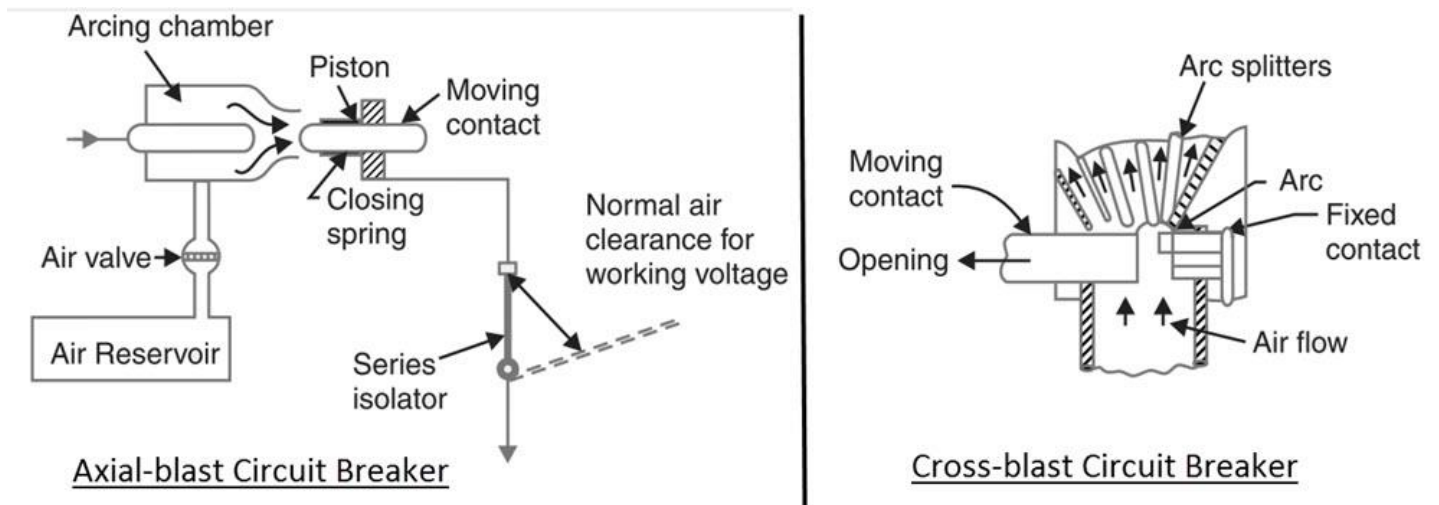

The air-blast in cross-blast type circuit breakers is perpendicular to the arc path and in radial-blast type circuit breakers, it is directed radially.

Advantages

- ✓ Risk of fire is eliminated.
- ✓ Arcing products are completely removed by the air-blast.
- ✓ Significantly faster increase in dielectric strength. Hence, the contact gap can be less, resulting in smaller device.
- ✓ Arcing time is very small and the arc energy is also small. Suitable for frequent operations.
- ✓ Air-blast is independent to the interrupting current.

Disadvantages

- ✓ Arc extinguishing properties of air are inferior.
- ✓ Sensitive to variations in restricting voltage.
- ✓ Air-blast compressor needs to be maintained.

Oil Circuit Breakers

In Oil Circuit Breakers, an insulating oil is used as the arc extinguishing medium. As the contacts are opened in oil, when the arc strikes, the surrounding oil is evaporated as hydrogen gas.

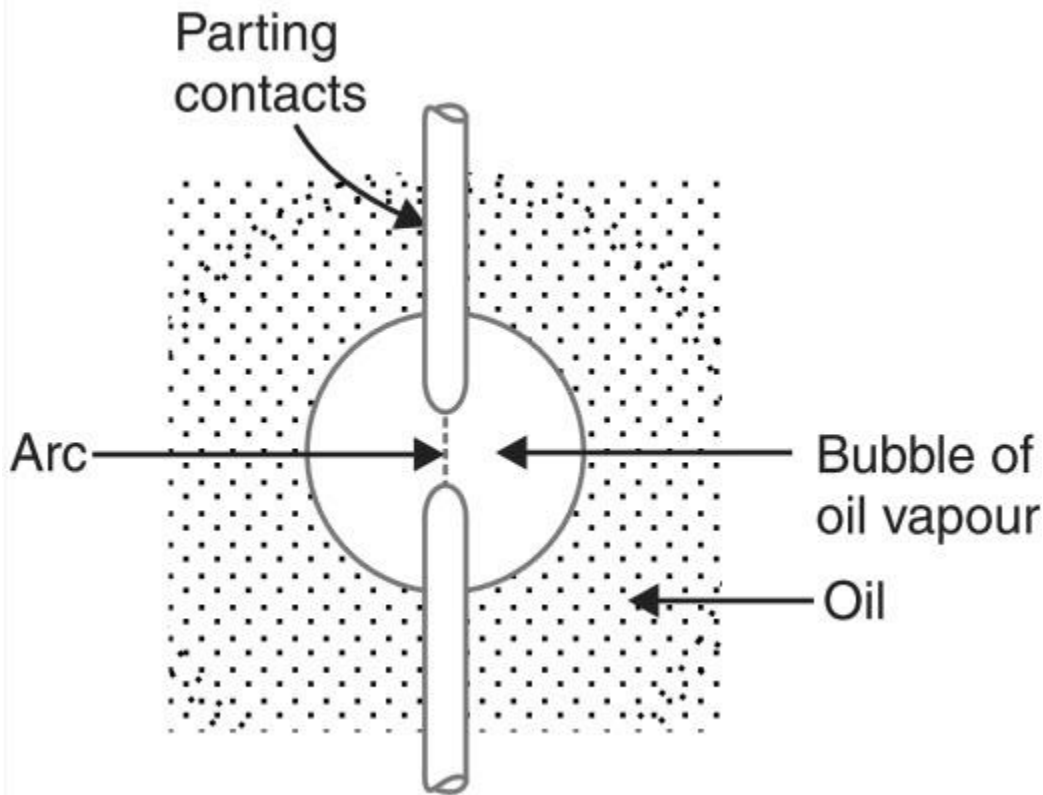

The hydrogen gas bubble will surround the arc region. Hydrogen gas, due to its high thermal conductivity, cools the arc and also deionizes the medium. Also, the gas causes turbulence in the surrounding oil and all the arcing products are pushed away from the arc.

There are two types of oil circuit breakers. They are:

1. Bulk Oil Circuit Breakers
2. Low Oil Circuit Breakers

As the name suggests, bulk oil circuit breakers use a significantly large quantity of oil. Further, bulk oil circuit breakers are again divided into two types.

1. Plain Break Oil Circuit Breakers
2. Arc Control Oil Circuit Breakers

In Plain Break Oil Circuit Breakers, the contacts are separated in the oil tank and the system for arc control is to increase the separation of the contacts. When a critical gap between the contacts is reached, the arc extinction occurs.

The lack of control over the arc in plain break oil circuit breakers is overcome in Arc Control Oil Circuit Breakers. The arc control is implemented in two ways known as:

1. Self-blast Oil Circuit Breakers
2. Forced-blast Oil Circuit Breakers

In self-blast type breakers, an insulating rigid pressure chamber is used with the contacts and the gases released during arcing are confined to this chamber or pot. The high pressure developed in the small chamber will force the oil as gas to go through the arc and subsequently extinguishing it.

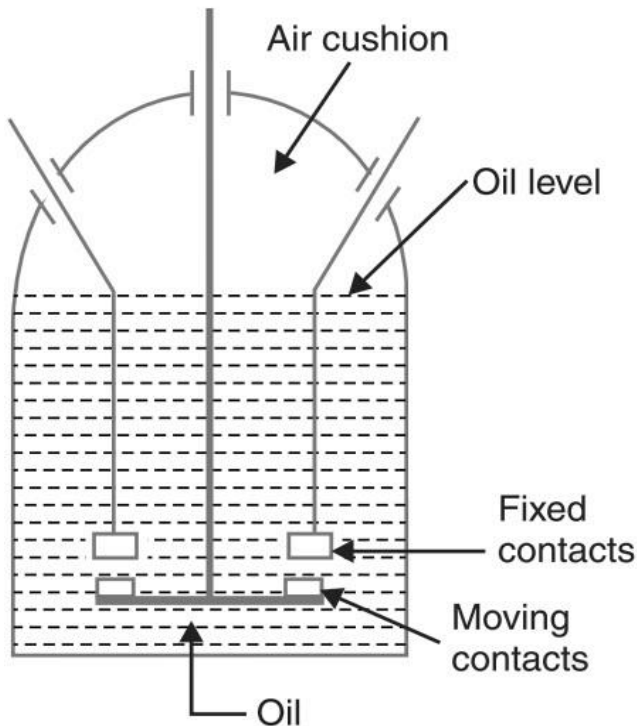

There are three type or designs of pressure pots in Self-blast Oil Circuit Breakers. They are:

1. Plain Explosion Pot
2. Cross Jet Explosion Pot
3. Self-compensated Explosion Pot

Coming to Forced-blast Oil Circuit Breakers, a piston cylinder is used to create the necessary oil pressure in contrast to Self-blast Oil Circuit Breakers, where the pressure is developed by the arc itself.

In all the Bulk Oil Circuit Breakers mentioned above, the oil has two jobs. One is to act as an arc extinguishing medium and the other is to insulate live circuit from earth. Only a small percentage (10% or less) is actually used for arc extinction and the majority of the oil is used for insulating purpose.

In Low Oil Circuit Breakers, oil is used for arc extinction and a solid material like porcelain and paper are used for insulation.

Advantages

- ✓ Oil has excellent cooling property and the arc energy converts the oil into gas.
- ✓ Acts as insulator between live wires and earth.

Disadvantages

- ✓ Oil is inflammable and is a fire hazard.
- ✓ Arcing products cannot escape and remain in the oil.

Maintenance of oil circuit breaker

- ✓ After a circuit breaker has interrupted by short-circuit current, sometimes their contacts may get burnt due to arcing. Also, the dielectric oil gets carbonized in the area of the contacts, thereby losing its dielectric strength.
- ✓ This results in the reduced breaking capacity of the breaker. Therefore, the maintenance of oil circuit breaker is essential for checking and replacement of oil and contacts.

Sulfur hexafluoride (SF₆) Circuit Breakers

- ✓ In Sulfur Hexafluoride circuit breakers, Sulfur Hexafluoride with chemical formula SF₆, is used as the arc extinguishing medium.
- ✓ The Sulfur hexafluoride gas is electro-negative in nature i.e. it attracts free electrons. When the circuit contacts are opened, a high pressure Sulfur hexafluoride gas flows through the chamber as the arc strikes.
- ✓ Free electrons produced during the arcing are quickly absorbed by the SF₆ gas resulting in immobile negative ions. As the arc loses its conducting electrons, the insulating strength of the surrounding medium is quickly increased and the arc completely extinguishes.
- ✓ Following image shows a simplified construction of SF₆ Circuit Breaker. Both the fixed and moving contacts are placed in arc chamber, which contains Sulfur hexafluoride gas. When the contacts open, a high pressure SF₆ gas from a reservoir will flow through the chamber's inlet.

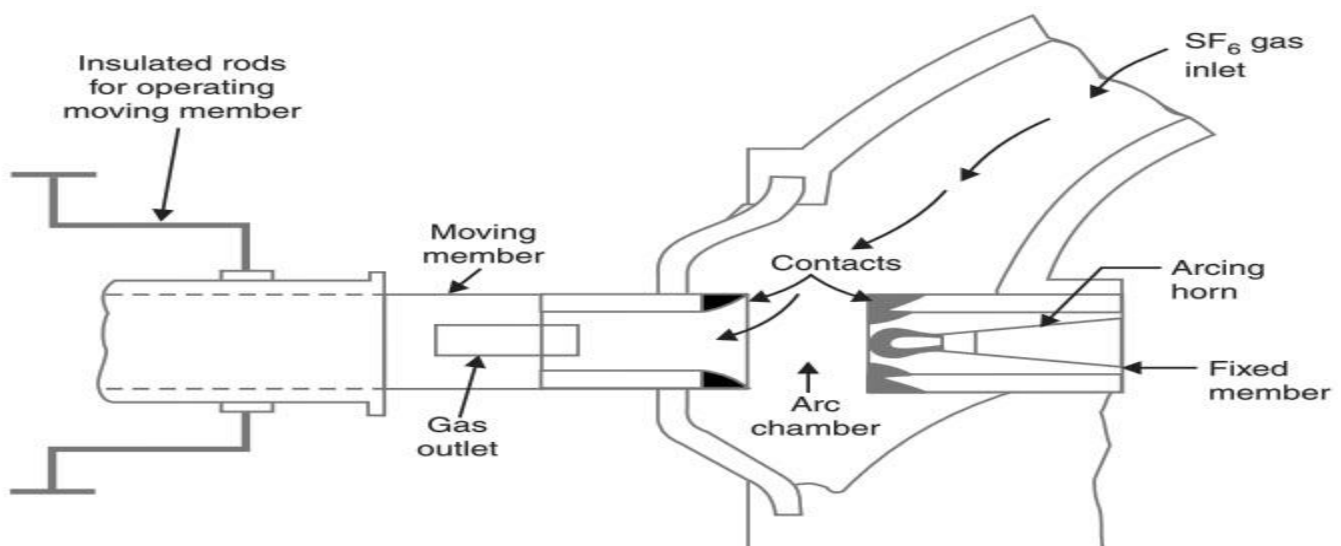

Advantages

- ✓ Superior arc extinguishing property.
- ✓ Can interrupt larger currents as the dielectric strength of SF₆ gas is almost 3 times greater than air.
- ✓ Noise free operation and no exhaust into atmosphere.
- ✓ Moisture free operation as the gas filled chamber keeps in interior dry.
- ✓ Very low maintenance and requires minimum equipment.

Disadvantages

- ✓ Sulfur hexafluoride gas is very costly.
- ✓ SF₆ has to be reconditioned after every operation.
- ✓ This high pressure Sulfur hexafluoride gas will absorb all the conducting free electrons and as a result causes the extinction of the arc.

Vacuum Circuit Breakers

- ✓ In vacuum circuit breakers or VCB, the arc extinguishing medium is, well Vacuum. It offers superior arc extinguishing properties than other medium as it has the highest insulating strength.
- ✓ When the contacts of the circuit breaker in vacuum are opened, an arc is formed due to ionization of the metal vapours of the contacts. But the arc is quickly extinguished as the vapours rapidly condense.
- ✓ A typical vacuum circuit breaker is shown in the following image. It consists of a moving contact and a fixed contact and also an arc shield mounted in a vacuum chamber. The outer insulating body is usually made up of glass or ceramic.

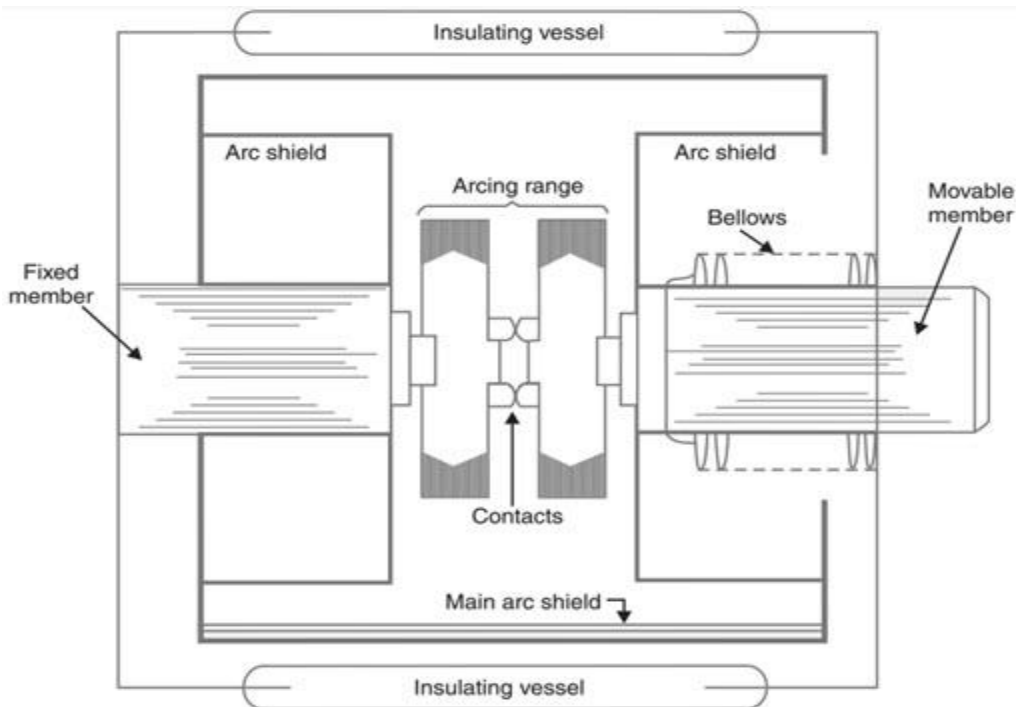

Advantages

- ✓ No fire hazards.
- ✓ Compact, very reliable and have very long life.
- ✓ No gas is generated during or after operation.
- ✓ No or very little maintenance.
- ✓ VCB can interrupt any fault current.
- ✓ Can withstand lightning strikes.
- ✓ Low arc energy is released.

Switchgear component:

The following are some important components common to Switchgear Components in Circuit Breakers :

1. Bushings
2. Circuit breaker contacts
3. Instrument transformers
4. Bus-bars and conductors

1. Bushings:

When a high voltage conductor passes through a metal sheet or frame which is at earth potential, the necessary insulation is provided in the form of bushing.

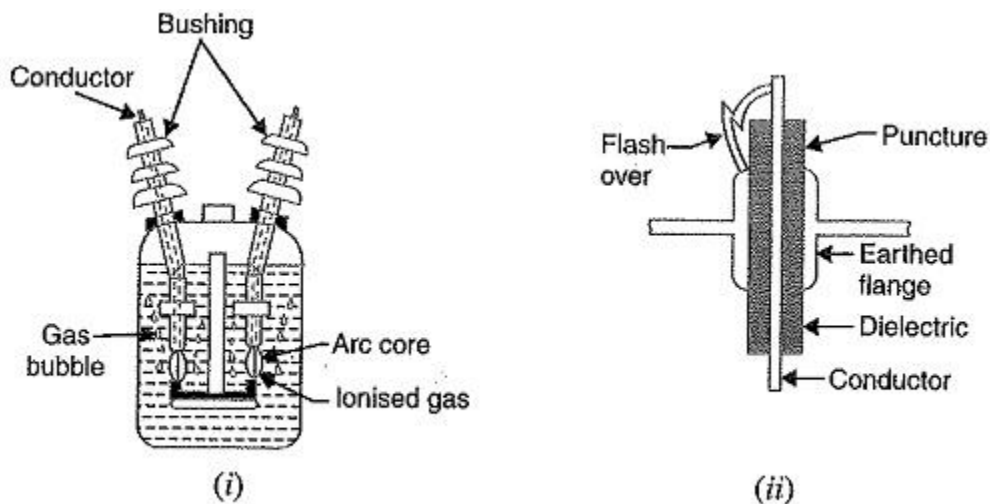

Fig. 19.13

The Primary function of the bushing is to prevent electrical breakdown between the enclosed conductor and the surrounding earthed metal work. Fig. 19.13 (i) shows the use of bushing for a plain-break oil circuit breaker. The high voltage conductor passes through the bushing made of some insulating material (e.g., porcelain, steatite). Although there are several types of bushing, they perform the same function of insulating the conductor from earthed tank.

Fig. 19.13 (ii) illustrates these two possibilities. The bushings are so designed that flash-over takes place before they get punctured. It is because the puncture generally renders the bushing insulation unserviceable

and incapable of withstanding the normal voltage. On the other hand, a flash-over may result in comparatively harmless burning of the surface of the bushing which can then continue to give adequate service pending replacement.

2. Circuit breaker contacts:

The circuit breaker contacts are required to carry normal as well as short-circuit current. In carrying the normal current, it is desirable that the temperature should not rise above the specified limits and that there should be low voltage drop at the point of contact. In carrying breaking and making short-circuit currents; therefore, the design of contacts is of considerable importance for satisfactory operation of the circuit breakers.

There are three types of circuit breaker contacts viz.

(a) Tulip type contacts:

Fig. 19.14 (i) shows the Tulip type contact. It consists, of moving contact which moves inside the fixed contacts. At contact separation, the arc is generally established between the tips of the fixed contacts and the tip of the moving contact as shown in Fig. 19.14 (ii). The advantage of this type of contact is that arcing is confined to the regions which are not in contact in the fully engaged position.

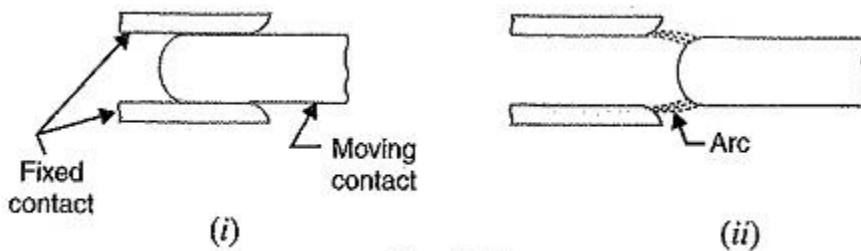

Fig. 19.14

(b) Finger and wedge contacts:

Fig. 19.15 (i) shows the finger and wedge type contact. This type of contact is largely used for low-voltage oil circuit breakers owing to the general unsuitability for use with arc control devices.

(c) Butt contacts:

Fig. 19.15 (ii) shows the butt type contact and is formed by the springs and the moving contact. It possesses two advantages. Firstly, spring pressure is available to assist contact separation. This is useful in single-break oil circuit breakers and air-blast circuit breakers where relatively small “loop” forces are available to assist in opening. Secondly, there is no grip force so that this type of contact is especially suitable for higher short-circuit rating.

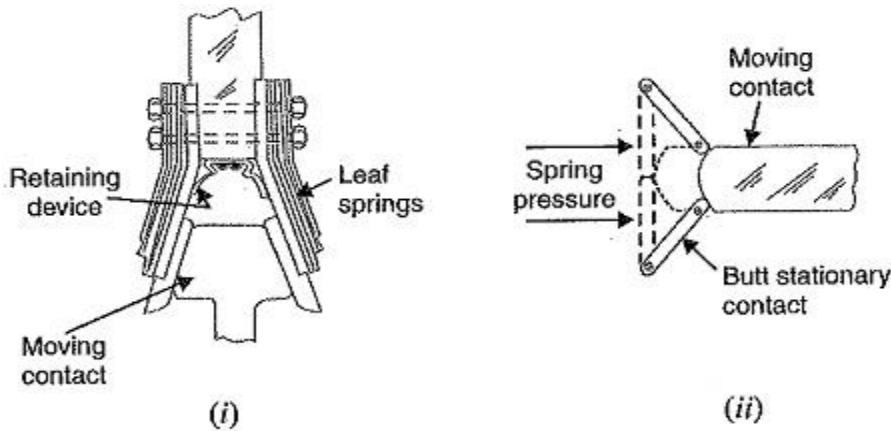

Fig. 19.15

3. Instrument transformers:

In a modern power system, the circuits operate at very high voltages and carry current of thousands of amperes. The measuring instruments and protective devices cannot work satisfactorily if mounted directly on the power lines. This difficulty is overcome by installing instrument transformers on the power lines.

There are two types of instrument transformers viz.

1. Current transformer (C.T.)
2. Potential transformer (P.T.)

The primary of current transformer is connected in the power line. The secondary winding provides for the instruments and relays a current which is a constant fraction of the current in the line.

Similarly, a potential transformer is connected with its primary in the power line. The secondary provides for the instruments and relays a voltage which is a known fraction of the line voltage.

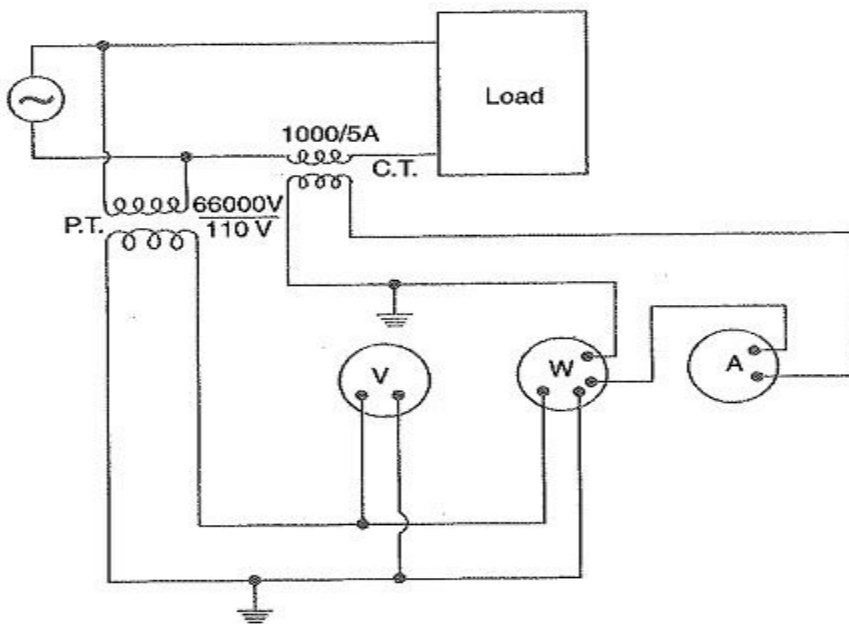

Fig. 19.16

Fig. 19.16 shows the use of instrument transformers. The potential transformer rated 66,000/ 110V provides a voltage supply for the potential coils of voltmeter and wattmeter. The current transformer rated 1000/5 A supplies current to the current coils of wattmeter and ammeter.

The use of instrument transformers permits the following advantages:

- ✓ They isolate the measuring instruments and relays from high-voltage power circuits.
- ✓ The leads in the secondary circuits carry relatively small voltages and currents. This permits to use wires of smaller size with minimum insulation.

4. Bus-bars and conductors:

The current carrying members in a circuit breaker consist of fixed and moving contacts and the conductors connecting these to the points external to the breaker. If the Switchgear Components in Circuit Breakers is of outdoor type, these connections are connected directly to the overhead lines. In case of indoor Switchgear Components in Circuit Breakers, the incoming conductors to the circuit breaker are connected to the bus-bars.

Problems of circuit interruption:

Following are the problems that occur when circuit breaker is clearing fault or CB starts operating

1. Rate of Rise of Restriking voltage (R.R.R.V.):

- ✓ Every line has some inductance L in series and some capacitance C in parallel to a generator. This arrangement is shown below.

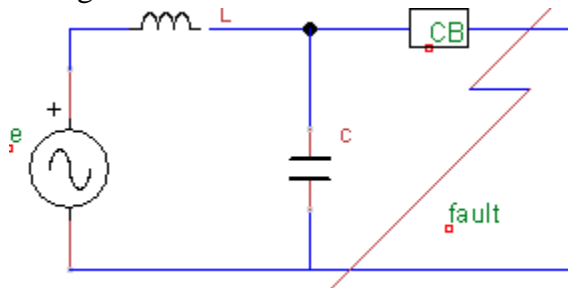

- ✓ When fault occurs, the current from generator has 2 paths. One through capacitor C and other through fault.
- ✓ The fault always offers very low resistance so all the current flows through fault and no current flow through C .
- ✓ As there is only one element in the circuit, the full voltage e will be given to L only.
- ✓ The current I_{sc} lags e by 90° (as the element is inductive)
- ✓ But when CB starts opening its contacts (moving contact and fixed contact are now separating) and arc is quenched then this circuit becomes series L - C circuit.

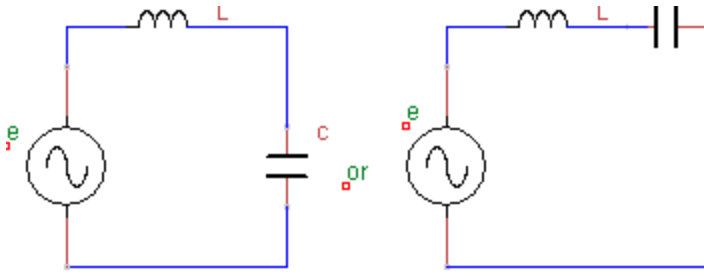

✓ Whenever L-C series circuit is form, a voltage is form which is called as Restriking voltage.

This Restriking voltage helps the arc to produce again. I.e. after quenching of arc this Restriking voltage produces arc again.

If Rate of Rising this Restriking voltage is more (RRRV is more) then arc forms again and again.

2. Current Chopping

✓ In circuit breaker, the AC current is interrupted when it is crossing zero. (i.e. SF6, Air etc is flow on arc at zero point because it is easy to quench arc at zero point).

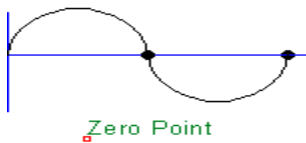

This problem of current chopping mainly occurs in Air-Blast circuit breaker, when some low current is (stopped or) interrupted.

✓ Current chopping is the process in which, when current is interrupted (stopped) before zero point then some very high voltage is develop between fixed contact and moving contact.

✓ This high voltage helps arc to form again.

✓ To solve this problem, we connected a Resistance in parallel with circuit breaker contacts.

If current is interrupted before zero point, this resistance will oppose high voltage and arc is not form again. This is also called as Resistance switching.

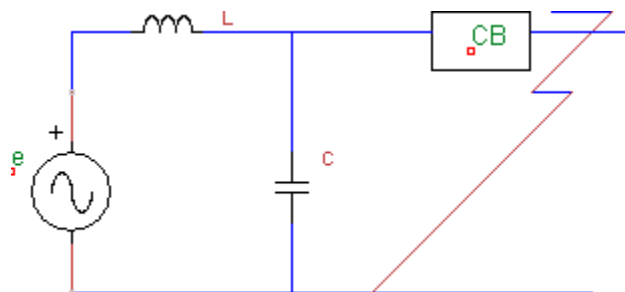

Current Chopping

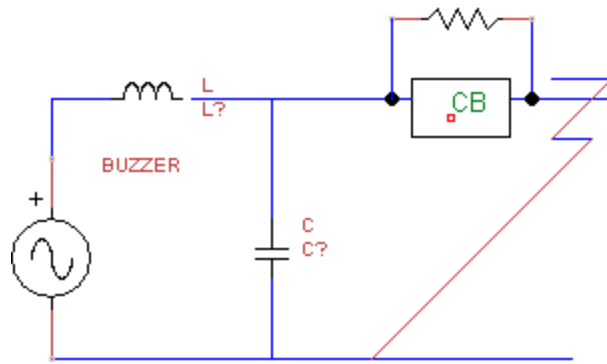

Resistance Switching (To reduce current chopping)

Resistance switching:

Resistance Switching in Circuit Breaker refers to a method adopted for dampening the over voltage transients due to current chopping, capacitive current breaking etc. In this method, a shunt resistance is connected across the contacts of circuit breaker.

How does Resistance Switching Work?

Let us consider a circuit and connect a shunt resistance R across the contacts of the breaker as shown below. Suppose a fault occurs on the line. Because of the occurrence of fault, the contacts of breaker will open and an arc will stuck between the contacts.

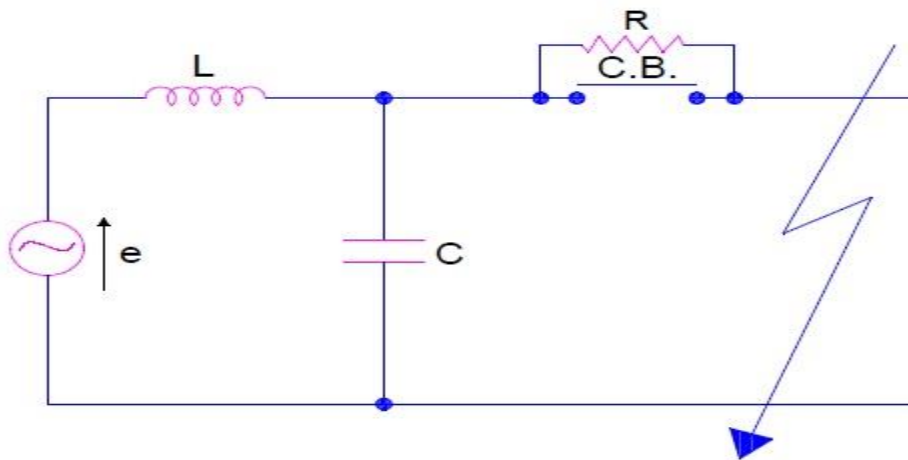

Resistance-switching

Since the contacts of breaker are shunted by resistance R, therefore a part of arc current will flow through this resistance R. Due to this the magnitude of arc current will reduce which in turn will result in increase in the rate of de-ionization of arc path. In this way, the arc resistance increases. This increased arc resistance leads to further increases in the current through the shunt resistance R. Thus again, the arc current will reduce and hence the arc resistance increases. This cumulative process will continue till the magnitude of arc current becomes so low that it is not able to maintain the arc. Thus the arc extinguishes and the current is interrupted by the breaker.

Resistance Switching also reduces the oscillatory growth of Re-striking Voltage. The natural frequency of the circuit shown above is given by

$$f_n = (1/2\pi)\sqrt{(1/LC - 1/4R^2C^2)}$$

The main role of shunt resistance R is to limit the growth of re-strike voltage and cause it to grow exponentially up to recovery voltage. If the value of R is so selected that the circuit becomes critically damped then re-strike voltage rises exponentially till recovery voltage is reached.

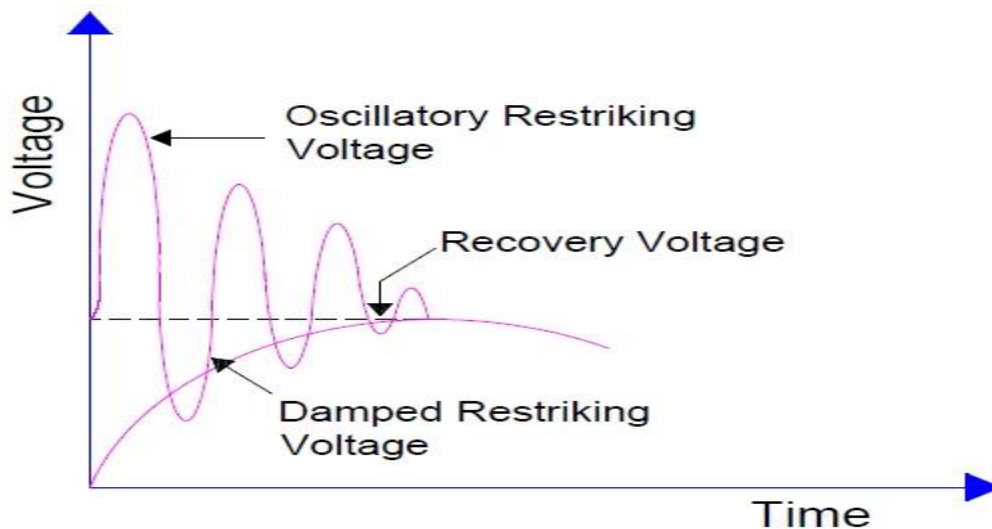

Resistance-switching-and-restriking-voltage

The value of R for critical damping can be find as

$$1/LC - 1/4R^2C^2 = 0$$

$$\Rightarrow 1/LC = 1/4R^2C^2$$

$$\Rightarrow L = 4R^2C$$

$$\Rightarrow R^2 = L / 4C$$

$$\Rightarrow R = 0.5 \sqrt{(L/C)}$$

Thus the advantages of resistance switching are as follows:

- ✓ It reduces the rate of rise of re-striking voltage and the peak value of re-striking voltage.
- ✓ Resistance Switching helps to reduce the voltage transient surge during current chopping and capacitive current breaking.

Circuit Breaker Rating:

The rating of the circuit breaker is given on the duties that are performed by it. For complete specification standard ratings and various tests of switches and circuit breakers may be consulted.

- ✓ It is capable of breaking the faulty section of the system. This is described as the breaking capacity of the circuit breaker.
- ✓ The circuit breaker must be capable of making the circuit in the greatest asymmetrical current in the current wave. This refers to making the capacity of the circuit breaker.
- ✓ It must be capable of carrying fault safely for a short time while the other breaker is clearing the fault. This refers to the short-time capacity of a circuit breaker.

In addition to the above rating, the circuit breakers should be specified in terms of

1. The number of poles
2. Rated voltage
3. Rated current
4. Rated frequency
5. Operating voltage

These terms are explained below in details

Rated voltage –

The rated maximum voltage of the circuit breaker is the highest RMS voltage, above nominal voltage for which the circuit breaker is designed and is the upper limits for operation. The rated voltage is depicted in KVrms and used phase to phase voltage for three phase circuit.

Rated current – The rated normal current of the circuit breaker is the RMS value of the current with which the circuit breaker shall be able to carry at rated frequency and at rated voltage continuously, under specified conditions.

Rated Frequency – The rated frequency of a circuit breaker is the frequency at which it is designed to operate. Standard frequency is 50 Hz

Operating Duty – The operating duty of a circuit breaker consists of the prescribed number of unit operations at stated intervals. The operating sequence refers the opening and closing operation of circuit breaker contacts.

Breaking Contact – The terms expressed the highest number of short-circuit current that the breakers are capable of breaking under specified conditions of transient recovery voltage and power frequency voltage. It is expressed in KA RMS at contact separation. The breaking capacities are divided into two types.

1. Symmetrical breaking capacity of a circuit breaker
2. Asymmetrical breaking capacity of a circuit breaker.

Making Capacity –

The making current of the circuit breaker, when closed on a short circuit, is the peak value of the maximum current wave (including dc component) in the first cycle of the current after the circuit is closed by the circuit breaker.

Short Circuit Current –

The short circuit current of a circuit breaker is the RMS value of current that a breaker can carry in a fully closed condition without damage, for the specified time interval under prescribed condition. It is normally expressed regarding terms of KA for 1 second or 4 seconds. These ratings are based on thermal limitation.

.....

UNIT-5

PROTECTIVE RELAYS

DEFINITION – *A protective relay is a device that detects the fault and intimate the operation of the circuit breaker to isolate the device element from the rest of the system.*

Fundamental Requirements of Protective Relay:

In order that protective relay system may perform this function satisfactorily, it should have the following qualities:

1. Selectivity
2. Speed
3. Sensitivity
4. Reliability
5. Simplicity
6. Economy

1. Selectivity: It is the ability of the protective system to select correctly that part of the system in trouble and disconnect the faulty part without disturbing the rest of the system.

2. Speed: The relay system should disconnect the faulty section as fast as possible for the following reasons

- ✓ Electrical apparatus may be damaged if they are made to carry the fault currents for a long time.
- ✓ A failure on the system leads to a great reduction in the system voltage. If the faulty section is not disconnected quickly, then the low voltage created by the fault may shut down consumers motors and the generators on the system may become unstable.
- ✓ The high speed relay system decreases the possibility of development of one type of fault into the other more severe type.

3. Sensitivity: It is the ability of the relay system to operate with low value of actuating quantity. Sensitivity of a relay is a function of the volt-amperes input to the coil of the relay necessary to cause its operation.

4. Reliability: It is the ability of the Protective Relay system to operate under the pre-determined conditions. Without reliability, the protection would be rendered largely ineffective and could even become a liability.

5. Simplicity: The relaying system should be simple so that it can be easily maintained. Reliability is closely related to simplicity. The simpler the protection scheme, the greater will be its reliability.

6. Economy: The most important factor in the choice of a particular protection scheme is the economic aspect. Sometimes it is economically unjustified to use an ideal scheme of protection and a compromise method has to be adopted. As a rule, the protective gear should not cost more than 5% of total cost.

Electromagnetic Attraction Relays:

Electromagnetic attraction relays operate by virtue of an armature being attracted to the poles of an electromagnet or a plunger being drawn into a solenoid. Such Basic Relays may be actuated by D.C. or A.C. quantities. The important types of electromagnetic attraction relays are :

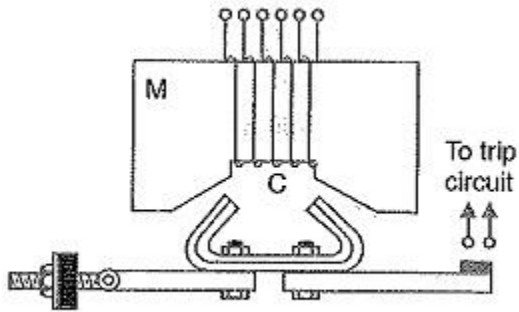

Fig. 21.3

(i) Attracted armature type relay:

- ✓ Fig. 21.3 shows the schematic arrangement of an attracted armature type relay. It consists of a laminated electromagnet M carrying a coil C and a pivoted laminated armature.
- ✓ The armature is balanced by a counterweight and carries a pair of spring contact fingers at its free end. Under normal operating conditions, the current through the relay coil C is such that counterweight holds the armature in the position shown.
- ✓ However, when a short circuit occurs, the current through the relay coil increases sufficiently and the relay armature is attracted upwards.
- ✓ The contacts on the Basic Relays armature bridge a pair of stationary contacts attached to the relay frame
- ✓ . This completes the trip circuit which results in the opening of the circuit breaker and, therefore, in the disconnection of the faulty circuit.
- ✓ The minimum current at which the relay armature is attracted to close the trip circuit is called pickup current.
- ✓ It is a usual practice to provide a number ofappings on the relay coil so that the number of turns in use and hence the setting value at which the relay operates can be varied.

(ii) Solenoid type relay:

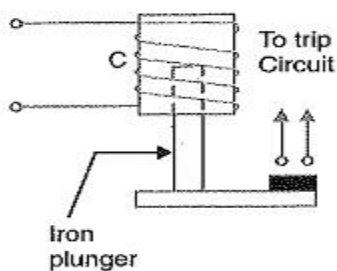

Fig. 21.4

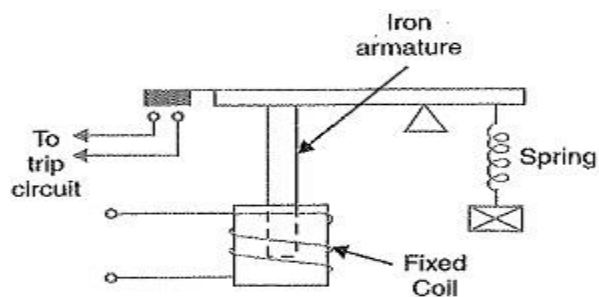

Fig. 21.5

- ✓ Fig. 21.4 shows the schematic arrangement of a solenoid type Basic Relays.
- ✓ It consists of a solenoid and movable iron plunger arranged as shown. Under normal operating conditions, the current through the relay coil C is such that it holds the plunger by gravity or spring in the position shown.
- ✓ However, on the occurrence of a fault, the current through the relay coil becomes more than the pickup value, causing the plunger to be attracted to the solenoid.
- ✓ The upward movement of the plunger closes the trip circuit, thus opening the circuit breaker and disconnecting the faulty circuit.

(iii) Balanced beam type relay:

- ✓ Fig. 21.5 shows the schematic arrangement of a balanced beam type relay. It consists of an iron armature fastened to a balance beam.
- ✓ Under normal operating conditions, the current through the relay coil is such that the beam is held in the horizontal position by the spring.
- ✓ However, when a fault occurs, the current through the relay coil becomes greater than the pickup value and the beam is attracted to close the trip circuit.
- ✓ This causes the opening of the circuit breaker to isolate the faulty circuit.

2. Electromagnetic Induction Relays:

- ✓ Electromagnetic induction relays operate on the principle of induction motor and are widely used for protective relaying purposes involving a.c. quantities.
- ✓ They are not used with D.C. quantities owing to the principle of operation. An induction relay essentially consists of a pivoted aluminum disc placed in two alternating magnetic fields of the same frequency but displaced in time and space.
- ✓ The torque is produced in the disc by the interaction of one of the magnetic fields with the currents induced in the disc by the other.
- ✓ To understand the production of torque in an induction relay, refer to the elementary arrangement shown in Fig. 21.6 (i).
- ✓ The two a.c. fluxes Φ_2 and Φ_1 differing in phase by an angle α induce e.m.f.s' in the disc and cause the circulation of eddy currents i_2 and i_1 respectively. These currents lag behind their respective fluxes by 90° .

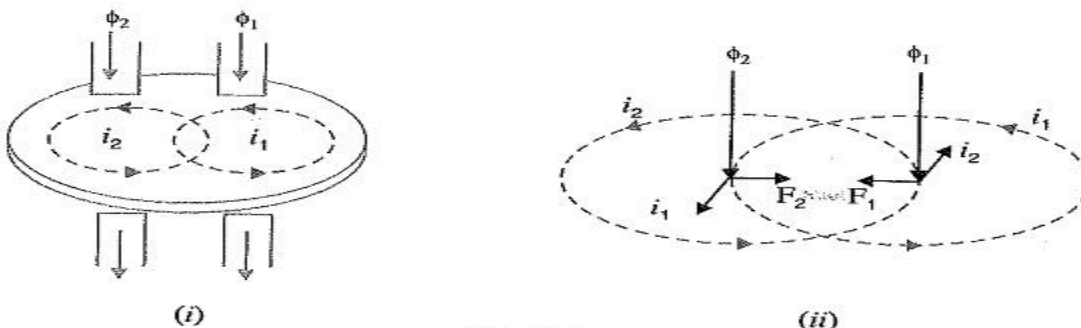

Fig. 21.6

Referring to Fig. 21.6 (ii) where the two a.c. fluxes and induced currents are shown separately for clarity, let

$$\begin{aligned}\phi_1 &= \phi_{1max} \sin \omega t \\ \phi_2 &= \phi_{2max} \sin (\omega t + \alpha)\end{aligned}$$

Where Φ_1 and Φ_2 are the instantaneous values of fluxes and Φ_2 leads Φ_1 by an angle α .

Assuming that the paths in which the rotor currents flow have negligible self-inductance, the rotor currents will be in phase with their voltages.

$$\begin{aligned}i_1 &\propto \frac{d\phi_1}{dt} \propto \frac{d}{dt} (\phi_{1max} \sin \omega t) \\ &\propto \phi_{1max} \cos \omega t \\ i_2 &\propto \frac{d\phi_2}{dt} \propto \phi_{2max} \cos (\omega t + \alpha) \\ F_1 &\propto \phi_1 i_2 \quad \text{and} \quad F_2 \propto \phi_2 i_1\end{aligned}$$

Fig 21.6 (ii) shows that the two forces are in opposition.

Net force F at the instant considered is

$$\begin{aligned}F &\propto F_2 - F_1 \\ &\propto \phi_2 i_1 - \phi_1 i_2 \\ &\propto \phi_{2max} \sin (\omega t + \alpha) \phi_{1max} \cos \omega t - \phi_{1max} \sin \omega t \phi_{2max} \cos (\omega t + \alpha) \\ &\propto \phi_{1max} \phi_{2max} [\sin (\omega t + \alpha) \cos \omega t - \sin \omega t \cos (\omega t + \alpha)] \\ &\propto \phi_{1max} \phi_{2max} \sin \alpha \\ &\propto \phi_1 \phi_2 \sin \alpha \quad \dots(i)\end{aligned}$$

Where Φ_1 and Φ_2 are the R.M.S. values of the fluxes.

The following three types of structures are commonly used for obtaining the phase difference in the fluxes and hence the operating torque in induction relays:

1. shaded-pole structure
2. watt hour-meter or double winding structure
3. induction cup structure

1. Shaded-pole structure:

The general arrangement of shaded-pole structure is shown in Fig. 21.7. It consists of a pivoted aluminum disc free to rotate in the air-gap of an electromagnet.

One-half of each pole of the magnet is surrounded by a copper band known as shading ring. The alternating flux Φ_s in the shaded portion of the poles will, owing to the reaction of the current induced in the ring, lag behind the flux Φ_u in the unshaded portion by an angle α .

These two a.c. fluxes differing in phase will produce the necessary torque to rotate the disc. As proved earlier, the driving torque T is given by

$$T \propto \phi_s \phi_u \sin \alpha$$

Assuming the fluxes Φ_s and Φ_u to be proportional to the current I in the relay coil,

$$T \propto I^2 \sin \alpha$$

This shows that driving torque is proportional to the square of current in the relay coil.

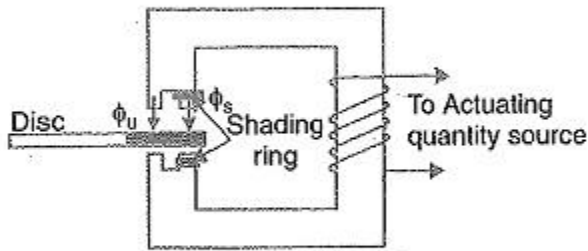

Fig. 21.7

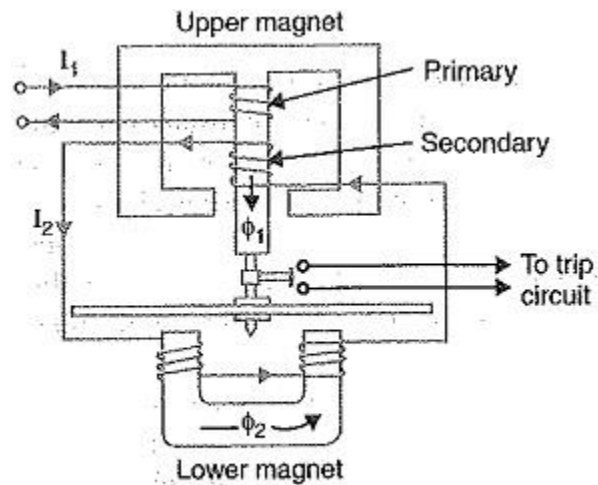

Fig. 21.8

Watt-hour meter structure:

- ✓ This structure gets its name from the fact that it is used in watt-hour meters. The general arrangement of this type of relay is shown in Fig. 21.8.
- ✓ It consists of a pivoted aluminum disc arranged to rotate freely between the poles of two electromagnets. The upper electromagnet carries two windings ; the primary and the secondary.
- ✓ The primary winding carries the relay current I_1 while the secondary winding is connected to the winding of the lower magnet. The primary current induces e.m.f. in the secondary and so circulates a current I_2 in it.
- ✓ The flux Φ_2 induced in the lower magnet by the current in the secondary winding of the upper magnet will lag behind Φ_1 by an angle α .
- ✓ The two fluxes Φ_1 and Φ_2 differing in phase by α will produce a driving torque on the disc proportional to $\Phi_1\Phi_2 \sin \alpha$.
- ✓ An important feature of this type of relay is that its operation can be controlled by opening or closing the secondary winding circuit.

- ✓ If this circuit is opened, no flux can be set by the lower magnet however great the value of current in the primary winding may be and consequently no torque will be produced.
- ✓ Therefore, the Basic Relays can be made inoperative by opening its secondary winding circuit.

3. Induction cup structure:

- ✓ Fig. 21.9 shows the general arrangement of an induction cup structure. It most closely resembles an induction motor, except that the rotor iron is stationary, only the rotor conductor portion being free to rotate.

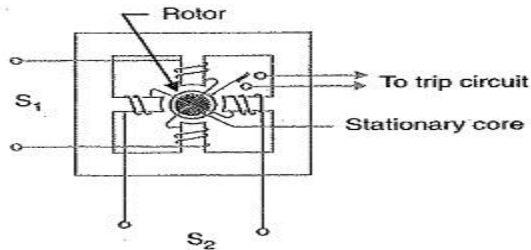

Fig. 21.9

- ✓ The moving element is a hollow cylindrical rotor which turns on its axis.
- ✓ The rotating field To trip circuit is produced by two St pairs of coils wound on four poles as shown. The rotating field induces currents in the cup to provide the necessary driving torque.
- ✓ If Φ_1 and Φ_2 represent the fluxes produced by the respective pairs of poles, then torque produced is proportional to $\Phi_1\Phi_2 \sin \alpha$ where α is the phase difference between the two fluxes.
- ✓ A control spring and the back stop for closing of the contacts carried on an arm are attached to the spindle of the cup to prevent the continuous rotation.

Definition of following important terms-

(i) **Pick-up current:** It is the minimum current in the relay coil at which the relay starts to operate.

(ii) **Current setting:** The pickup value of current can be adjusted to the required level in the relays which is called current setting of that relay.

$$\text{Pick-up current} = \text{Rated secondary current of C.T.} \times \text{Current setting}$$

Plug Setting Multiplier (PSM):

Plug Setting Multiplier (PSM) is defined as the ratio of fault current to the pick-up current of the relay. Thus,

$$\begin{aligned} \text{PSM} &= \text{Fault Current} / \text{Pick-up Current} \\ &= \text{Fault Current} / (\text{Plug Position} \times \text{Rated CT Secondary Current}) \end{aligned}$$

Suppose we are using CT of 100/1 A, a fault current of, say 5000 A is flowing through the network protected by the relay.

$$\text{Fault current in CT secondary} = (5000 \times 1) / 100 = 50 \text{ A}$$

Assume that Current Setting or the position of plug is at 5 then

$$PSM = 50 / (1 \times 5) = 10$$

Time Setting Multiplier (TSM): A Relay is generally provided with control to adjust the time of operation of the Relay. This adjustment is known as Time Setting Multiplier or TSM. Normally a Time Setting Dial is provided which is calibrated from 0 to 1 s in step of 0.05 s.

Classification of functional relays-

1. Induction type overcurrent relays
2. Induction type reverse power relays
3. Distance relays
4. Differential relays
5. Translay scheme

Induction Type Overcurrent Relay (Non-Directional):

This Induction Type Overcurrent Relay works on the induction principle and initiates corrective measures when current in the circuit exceeds the predetermined value. The actuating source is a current in the circuit supplied to the relay from a current transformer. These relays are used on a .c. circuits only and can operate for fault current flow in either direction.

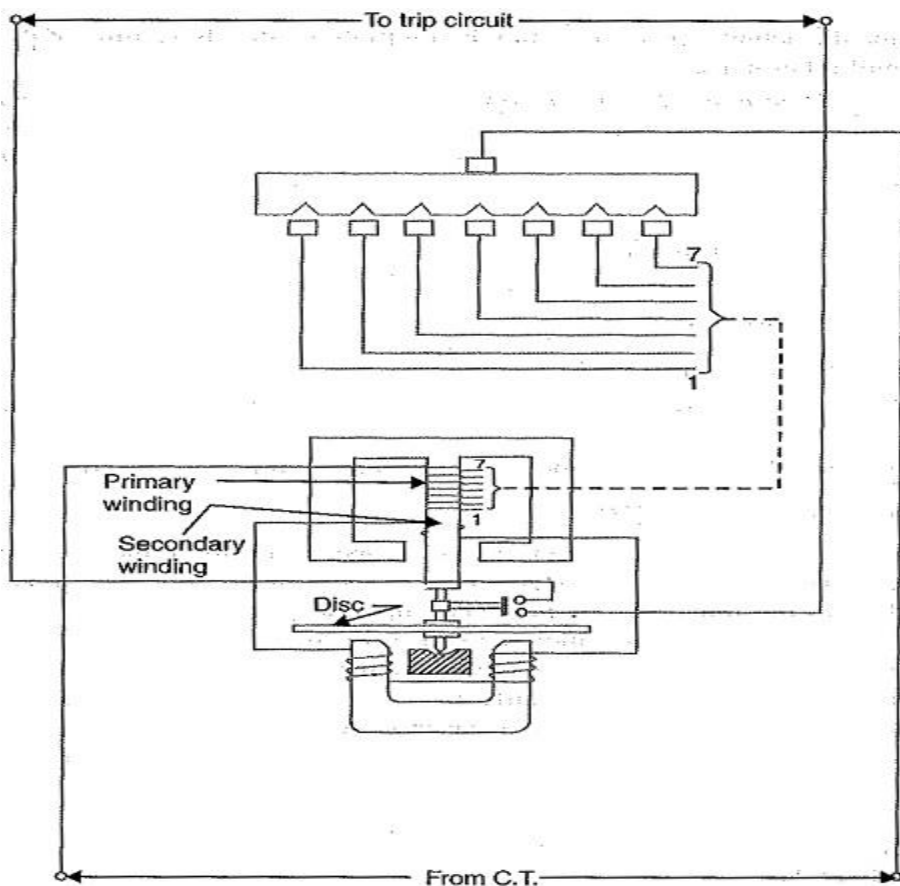

Fig. 21 .17

Constructional details:

- ✓ Fig. 21.17 shows the, important constructional details of a typical non-directional induction type overcurrent relay. It consists of a metallic (aluminium) disc which is free to rotate in between the poles of two electromagnets.
- ✓ The upper electromagnet has a primary and a secondary winding. The primary is connected to the secondary of a C.T. in the line to be protected and is tapped at intervals.
- ✓ The tapplings are connected to a plug-setting bridge by which the number of active turns on the relay operating coil can be varied, thereby giving the desired current setting.
- ✓ The secondary winding is energized by induction from primary and is connected in series with the winding on the lower magnet. The controlling torque, is provided by a spiral spring.
- ✓ The spindle of the disc carries a moving contact which bridges two fixed contacts (connected to trip circuit) when the disc rotates through a pre-set angle.
- ✓ This angle can be adjusted to any value between 0° and 360° . By adjusting this angle, the travel of the moving contact can be adjusted and hence the relay can be given any desired time setting.

Operation:

- ✓ The driving torque on the aluminium disc is set up due to the induction principle. This torque is opposed by the restraining torque provided by the spring.
- ✓ Under normal operating conditions, restraining torque is greater than the driving torque produced by the relay coil current, therefore, the aluminium disc remains stationary.
- ✓ However, if the current in the protected circuit exceeds the pre-set value, the driving torque becomes greater than the restraining torque.
- ✓ Consequently, the disc rotates and the moving contact bridges the fixed contacts when the disc has rotated through a pre-set angle. The trip circuit operates the circuit breaker which isolates the faulty section.

Induction type directional power relay:

This Induction Type Directional Power Relay operates when power in the circuit flows in a specific direction Unlike a non-directional overcurrent relay, a directional power relay is so designed that it obtains its operating torque by the interaction of magnetic fields derived from both voltage and current source of the circuit it protects. Thus this type of relay is essentially a wattmeter and the direction of the torque set up in the relay depends upon the direction of the current relative to the voltage, with which it is associated.

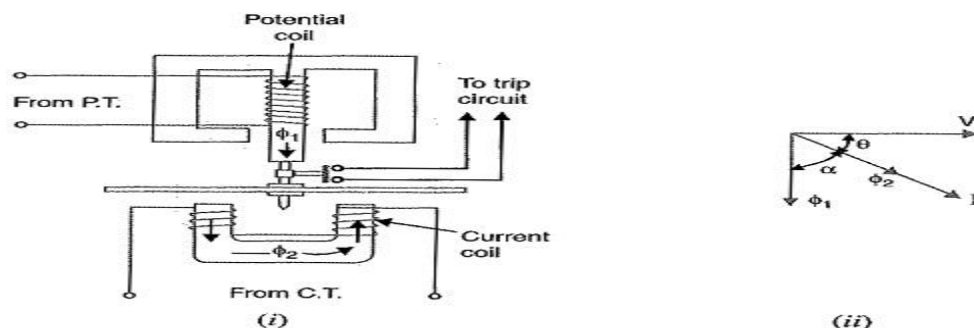

Fig. 21.18

Constructional details:

- ✓ Fig. 21.18 shows the essential parts of a typical induction type directional power relay. It consists of an aluminum disc which is free to rotate in between the poles of two electromagnets.
- ✓ The upper electromagnet carries a winding (called potential coil) on the central limb which is connected through a potential transformer (P.T.) to the circuit voltage source.
- ✓ The lower electromagnet has a separate winding (called current coil) connected to the secondary of C.T. in the line to be protected.
- ✓ The current coil is provided with a number of tappings connected to the plug-setting Midge (not shown for clarity). This permits to have any desired current setting. The restraining torque is provided by a spiral spring.
- ✓ The spindle of the disc carries a moving contact which bridges two fixed contacts when the disc has rotated through a pre-set angle. By adjusting this angle, the travel of the moving disc can be adjusted and hence any desired time-setting can be given to the relay.

Operation: The flux Φ_1 due to current in the potential coil will be nearly 90° lagging behind the applied voltage V . The flux Φ_2 due to current coil will be nearly in phase with the operating current I .

The interaction of fluxes Φ_1 and Φ_2 with the eddy currents induced in the disc produces a driving torque given by:

$$T \propto \phi_1 \phi_2 \sin \alpha \quad [\text{See Art. 21.5}]$$

$$\text{Since } \phi_1 \propto V, \quad \phi_2 \propto I \quad \text{and} \quad \alpha = 90 - \theta$$

$$T \propto VI \sin (90 - \theta)$$

$$\propto VI \cos \theta$$

$$\propto \text{power in the circuit}$$

- ✓ It is clear that the direction of driving torque on the disc depends upon the direction of power flow in the circuit to which the relay is associated.
- ✓ When the power in the circuit flows in the normal direction, the driving torque and the restraining torque (due to spring) help each other to turn away the moving contact from the fixed contacts. Consequently, the relay remains inoperative.
- ✓ However, the reversal of current in the circuit reverses the direction of driving torque on the disc.
- ✓ When the reversed driving torque is large enough, the disc rotates in the reverse direction and the moving contact closes the trip circuit. This causes the operation of the circuit breaker which disconnects the faulty section.

Induction Type Directional Overcurrent Relay:

- ✓ The directional power relay is unsuitable for use as a directional protective relay under short-circuit conditions.
- ✓ When a short-circuit occurs, the system voltage falls to a low value and there may be insufficient torque developed in the relay to cause its operation.

- ✓ This difficulty is overcome in the Induction Type Directional Overcurrent Relay which is designed to be almost independent of system voltage and power factor

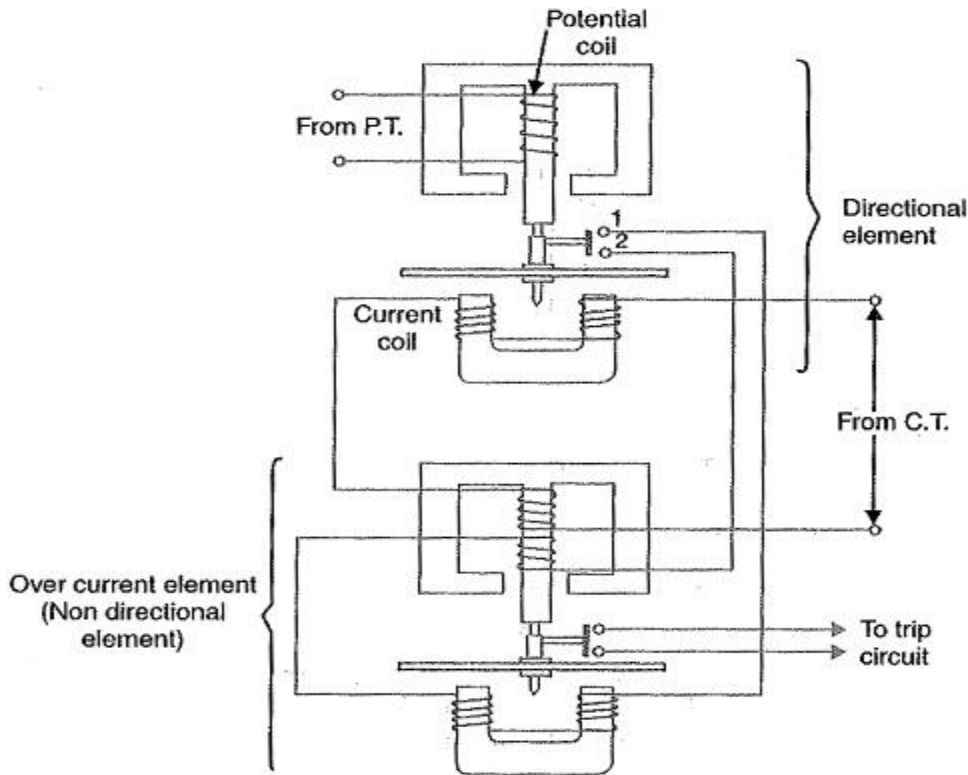

Fig. 21.19

Constructional details: Fig. 21.19 shows the constructional details of a typical Induction Type Directional Overcurrent Relay. It consists of two relay elements mounted on a common case viz.

1. Directional element and
2. Non-directional element.

1. Directional element:

- ✓ It is essentially a directional power relay which operates when power flows in a specific direction. The potential coil of this element is connected through a potential transformer (P.T.) to the system voltage.
- ✓ The current coil of the element is energized through a C.T. by the circuit current. This winding is carried over the upper magnet of the non-directional element.
- ✓ The trip contacts (1 and 2) of the directional element are connected in series with the secondary circuit of the overcurrent element.

- ✓ Therefore, the latter element cannot start to operate until its secondary circuit is completed. In other words, the directional element must operate first (i.e. contacts I and 2 should close) in order to operate the overcurrent element.
- ✓ **Non-directional element:** It is an overcurrent element similar in all respects to a non-directional overcurrent relay described in Art. 21.11.
- ✓ The spindle of the disc of this element carries a moving contact which closes the fixed contacts (trip circuit contacts) after the operation of directional element.
- ✓ It may be noted that plug-setting bridge is also provided in the relay for current setting but has been omitted in the figure for clarity and simplicity.
- ✓ The tapplings are provided on the upper magnet of overcurrent element and are connected to the bridge.

Operation:

- ✓ Under normal operating conditions, power flows in the normal direction in the circuit protected by the relay.
- ✓ Therefore, Induction Type Directional Overcurrent Relay (upper element) does not operate, thereby keeping the overcurrent element (lower element) unenergised.
- ✓ However, when a short-circuit occurs, there is a tendency for the current or power to flow in the reverse direction. Should this happen, the disc of the upper element rotates to bridge the fixed contacts 1 and 2. This completes the circuit for overcurrent element.
- ✓ The disc of this element rotates and the moving contact attached to it closes the trip circuit. This operates the circuit breaker which isolates the faulty section.
- ✓ The two relay elements are so arranged that final tripping of the current controlled by them is not made till the following conditions are satisfied :
 1. Current flows in a direction such as to operate the directional element.
 2. Current in the reverse direction exceeds the pre-set value.
 3. Excessive current persists for a period corresponding to the time setting of overcurrent element.

Differential Relay:

A differential relay is one that operates when the phasor difference of two or more similar electrical quantities exceeds a pre-determined value.

1. Current balance protection
2. Voltage balance protection

Current Differential Relay:

- ✓ Fig. 21.23 shows an arrangement of an over current relay connected to operate as a differential relay.
- ✓ A pair of identical current transformers is fitted on either end of the section to be protected (alternator winding in this case).

- ✓ The secondaries of CT's are connected in series in such a way that they carry the induced currents in the same direction.
- ✓ The operating coil of the over current relay is connected across the CT secondary circuit. This differential relay compares the current at the two ends of the alternator winding.
- ✓ Under normal operating conditions, suppose the alternator winding carries a normal current of 1000 A. Then the currents in the two secondaries of CT's are equal [See Fig. 21.23].
- ✓ These currents will merely circulate between the two CT's and no current will flow through the differential relay. Therefore, the relay remains inoperative.

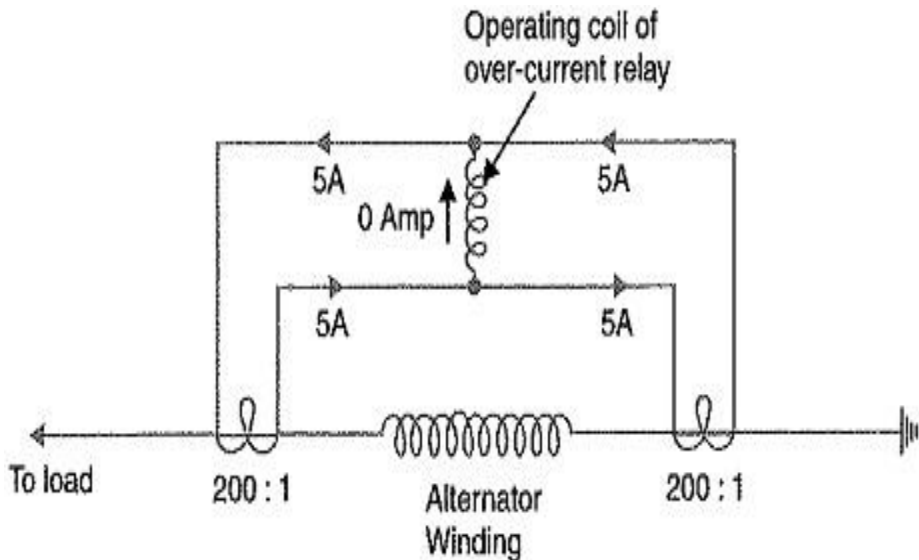
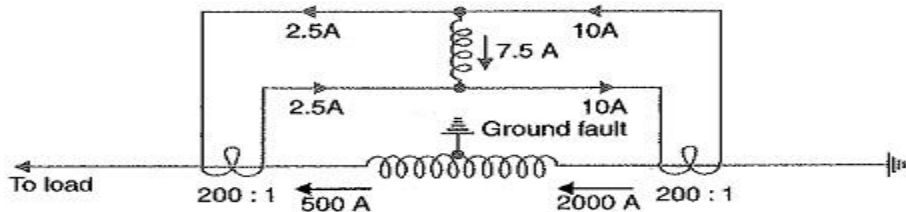
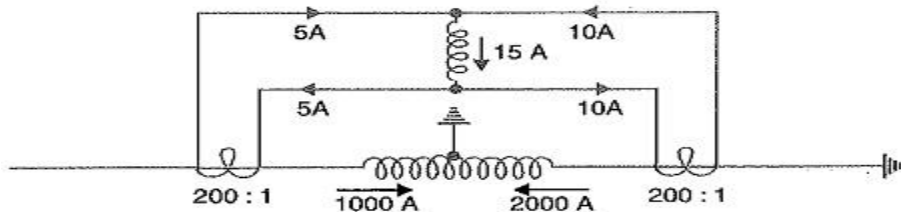

Fig. 21.23

- ✓ If a ground fault occurs on the alternator winding as shown in Fig. 21.24 (i), the two secondary currents will not be equal and the current flows through the operating coil of the relay, causing the relay to operate. The amount of current flow through the relay will depend upon the way the fault is being fed.



(i)



(ii)

Fig. 21.24

- ✓ If some current (500 A in this case) flows out of one side while a larger current (2000 A) enters the other side as shown in Fig. 21.24 (i), then the difference of the CT secondary currents i.e. $10 - 2.5 = 7.5$ A will flow through the relay.
- ✓ If current flows to the fault from both sides as shown in Fig. 21.24 (ii), then sum of CT secondary currents i.e. $10 + 5 = 15$ A will flow through the relay.

Disadvantages of Current Differential Relay:

- ✓ The impedance of the pilot cables generally causes a slight difference between the currents at the two ends of the section to be protected. If the relay is very sensitive, then the small differential current flowing through the relay may cause it to operate even under no fault
- ✓ Pilot cable capacitance causes incorrect operation of the relay when a large through-current
- ✓ Accurate matching of current transformers cannot be achieved due to pilot circuit impedance.

Voltage Balance Differential Relay:

- ✓ Fig. 21.27 shows the arrangement of voltage balance protection.
- ✓ In this scheme of protection, two similar current transformers are connected at either end of the element to be protected (e.g. an alternator winding) by means of pilot wires.
- ✓ The secondaries of current transformers are connected in series with a relay in such way that under normal conditions, their induced e.m.f.s' are in opposition.

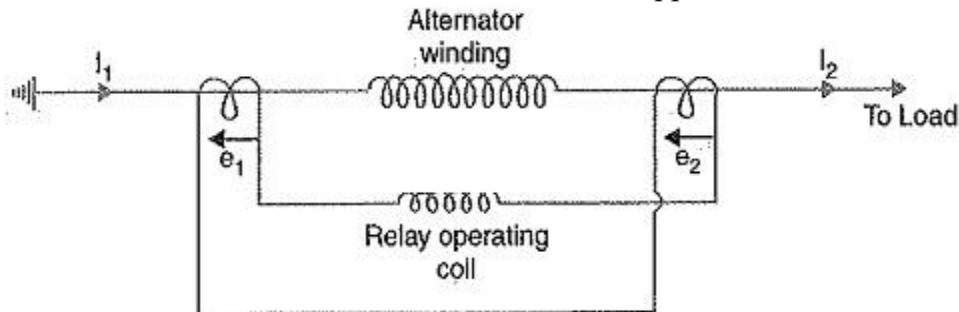

Fig. 21.27

- ✓ Under healthy conditions, equal currents ($I_1 = I_2$) flow in both primary windings.
- ✓ Therefore, the secondary voltages of the two transformers are balanced against each other and no current will flow through the relay operating coil.
- ✓ When a fault occurs in the protected zone, the currents in the two primaries will differ from one another (i.e. $I_1 \neq I_2$) and their secondary voltages will no longer be in balance.
- ✓ This voltage difference will cause a current to flow through the operating coil of the relay which closes the trip circuit.

Disadvantages in Voltage Balance Differential Relay:

- ✓ The voltage balance system suffers from the following drawbacks:
- ✓ A multi-gap transformer constriction is required to achieve the accurate balance between current transformer pairs.
- ✓ The system is suitable for protection of cables of relatively short lengths due to the capacitance of pilot wires. On long, cables, the charging current may be sufficient to operate the relay even if a perfect balance of current transformers is attained.

Types of Protection:

When a fault occurs on any part of electric power system, it must be cleared quickly in order to avoid damage and/or interference with the rest of the system. It is a usual practice to divide the Types of Protection scheme into two classes viz. **primary protection and back-up protection.**

Primary Protection: It is the protection scheme which is designed to protect the component parts of the power system.

- ✓ Thus referring to Fig. 21.29, each line has an overcurrent relay that protects the line. If a fault occurs on any line, it will be cleared by its relay and circuit breaker.
- ✓ This forms the primary or main protection and serves as the first line of defence.
- ✓ The service record of primary relaying is very high with well over ninety percent of all operations being correct.
- ✓ However, sometimes faults are not cleared by primary relay system because of trouble within the relay, wiring system or breaker. Under such conditions, back-up protection does the required job

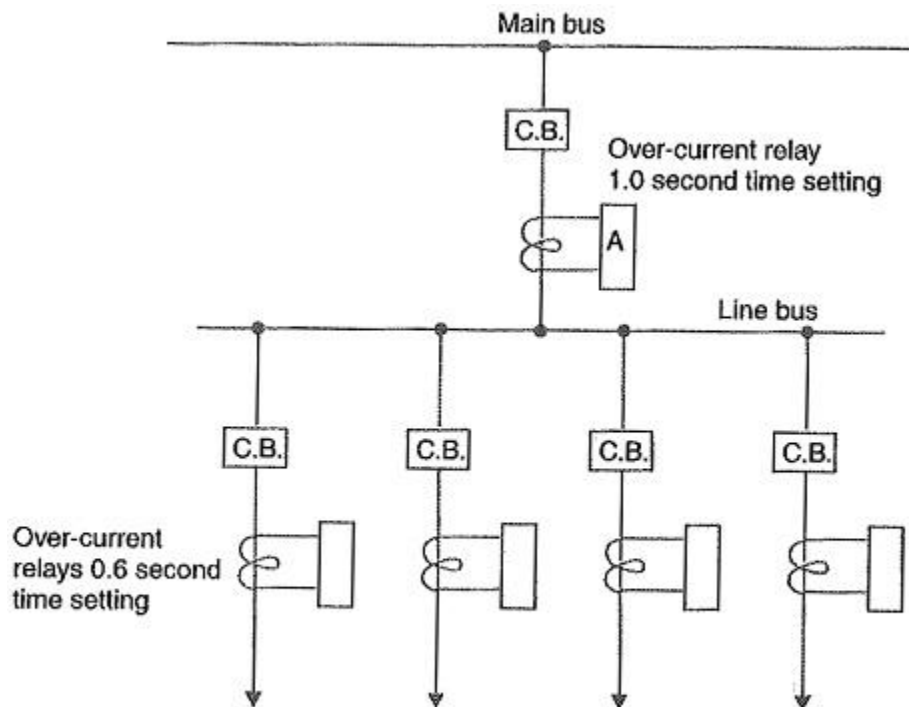

Fig. 21.29

2. Back-up protection: It is the second line of defense in case of failure of the primary protection. It is designed to operate with sufficient time delay so that primary relaying will be given enough time to function if it is able to. Thus referring to Fig. 21.29, relay A provides back-up protection for each of the four lines. If a line fault is not cleared by its relay and breaker, the relay A on the group breaker will operate after a definite time delay and clear the entire group of lines.

.....

UNIT-6

PROTECTION OF ELECTRICAL POWER EQUIPMENT AND LINES

Protection of Alternators:

The generating units, especially the larger ones, are relatively few in number and higher in individual cost than most other equipment's. Therefore, it is desirable and necessary to provide Protection of Alternators to cover the wide range of faults which may occur in the modern generating plant.

Some of the important faults which may occur on an alternator are:

1. Failure of prime-mover
2. Failure of field
3. Overcurrent
4. Overspeed
5. Overvoltage
6. Unbalanced loading
7. Stator winding faults

1. Failure of Prime-Mover: When input to the prime-mover fails, the alternator runs as a synchronous motor and draws some current from the supply system. This motoring conditions is known as “inverted running“.

2. Failure of field: The chances of field failure of alternators are undoubtedly very rare. Even if it does occur, no immediate damage will be caused by permitting the alternator to run without a field for a short-period. It is sufficient to rely on the control room attendant to disconnect the faulty alternator manually from the system bus-bars. Therefore, it is a universal practice not to provide automatic protection against this contingency.

3. Overcurrent: It occurs mainly due to partial breakdown of winding insulation or due to overload on the supply system. Overcurrent protection for alternators is considered unnecessary because of the following reasons :

- ✓ The modern tendency is to design alternators with very high values of internal impedance so that they will stand a complete short-circuit at their terminals for sufficient time without serious overheating. On the occurrence of an overload, the alternators can be disconnected manually.
- ✓ The disadvantage of using overload Protection of Alternators is that such a protection might disconnect the alternators from the power plant bus on account of some momentary troubles outside the plant and, therefore, interfere with the continuity of electric service.

4. Overspeed: The chief cause of overspeed is the sudden loss of all or the major part of load on the alternator. Modern alternators are usually provided with mechanical centrifugal devices mounted on their driving shafts to trip the main valve of the prime-mover when a dangerous overspeed occurs.

5. Over-voltage: The field excitation system of modern alternators is so designed that over-voltage conditions at normal running speeds cannot occur. However, over voltage in an alternator occurs when speed of the prime-mover increases due to sudden loss of the alternator load.

6. Unbalanced loading: Unbalanced loading means that there are different phase currents in the alternator. Unbalanced loading arises from faults to earth or faults between phases on the circuit external to the alternator.

7. Stator winding faults: These faults occur mainly due to the insulation failure of the stator windings. The main types of stator winding faults, in order of importance are:

- ✓ fault between phase and ground
- ✓ fault between phases
- ✓ inter-turn fault involving turns of the same phase winding

Differential protection of alternators:

- ✓ The most common system used for the protection of stator winding faults employs circulating-current principle .
- ✓ In this scheme of Differential Protection of Alternators, currents at the two ends of the protected section are compared. Under normal operating conditions, these currents are equal but may become unequal on the occurrence of a fault in the protected section.
- ✓ The difference of the currents under fault conditions is arranged to pass through the operating coil of the relay. The relay then closes its contacts to isolate protected section from the system. This form of protection is also known as Merz-Price Circulating Current Scheme.

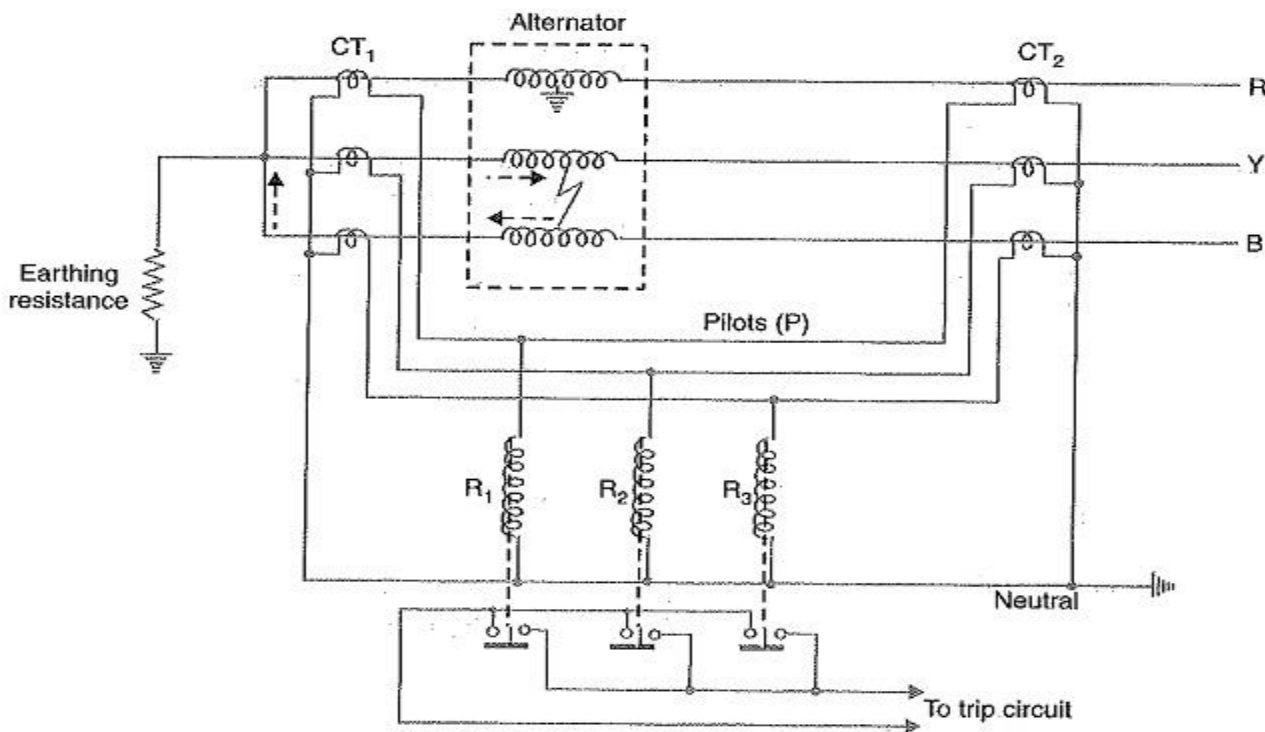

Fig. 22.2

Schematic arrangement:

- ✓ Fig. 22.2 shows the schematic arrangement of Differential Protection of Alternators for a 3-phase alternator. Identical current transformer pairs CT1 and CT2 are placed on either side of each phase of the stator windings.
- ✓ The secondaries of each set of current transformers are connected in star ; the two neutral points and the corresponding terminals of the two star groups being connected together by means of a four-core pilot cable.
- ✓ Thus there is an independent path for the currents circulating in each pair of current transformers and the corresponding pilot P.
- ✓ The relay coils are connected in star, the neutral point being connected to the current-trans-former common neutral and the outer ends one to each of the other three pilots.
- ✓ In order that burden on each current transformer is the same, the relays are connected across equipotential points of the three pilot wires and these equipotential points would naturally be located at the middle of the pilot wires.
- ✓ The relays are generally of electromagnetic type and are arranged for instantaneous action since fault should be cleared as quickly as possible.

Operation:

- ✓ Referring to Fig. 22.2, it is clear that the relays are connected in shunt across each circulating path. Therefore, the circuit of Fig. 22.2 can be shown in a simpler form in Fig. 22.3.
- ✓ Under normal operating conditions, the current at both ends of each winding will be equal and hence the currents in the secondaries of two CTs connected in any phase will also be equal.
- ✓ Therefore, there is balanced circulating current in the pilot wires and no current flows through the operating coils (R1, R2 and R3) of the relays.
- ✓ When an earth-fault or phase-to-phase fault occurs, this condition no longer holds good and the differential current flowing through the relay circuit operates the relay to trip the circuit breaker.

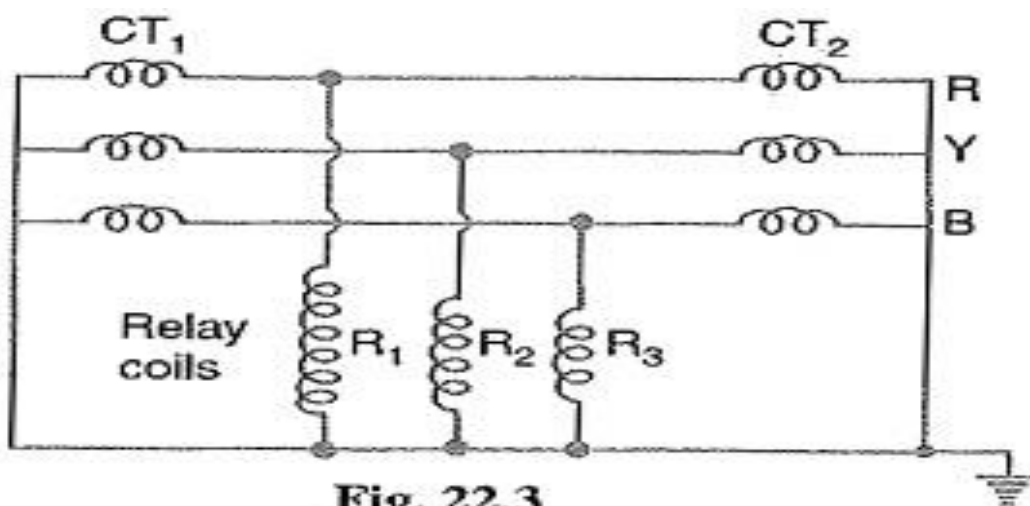

Fig. 22.3

1. Suppose an earth fault occurs on phase R due to breakdown of its insulation to earth as shown in Fig. 22.2. The current in the affected phase winding will flow through the core and frame of the machine to earth, the circuit being completed through the neutral earthing resistance. The currents in the secondaries of the two CTs in phase R will become unequal and the difference of the two currents will flow through the corresponding relay coil (i.e. R1), returning via the neutral pilot. Consequently, the relay operates to trip the circuit breaker.
2. Imagine that now a short-circuit fault occurs between the phases Y and B as shown in Fig. 22.2. The short-circuit current circulates via the neutral end connection through the two windings and through the fault as shown by the dotted arrows. The currents in the secondaries of two CTs in each affected phase will become unequal and the differential current will flow through the operating coils of the relays (i.e. R2 and R3) connected in these phases. The relay then closes its contacts to trip the circuit breaker.

Limitations:

- ✓ The two circuits for alternator protection shown above have their own limitations. It is a general practice to use neutral earthing resistance in order to limit the destructive effects of earth-fault currents. In such a situation, it is impossible to protect whole of the stator windings of a star-connected alternator during earth-faults.
- ✓ When an earth-fault occurs near the neutral point, there may be insufficient voltage across the short-circuited portion to drive the necessary current round the fault circuit to operate the relay. The magnitude of unprotected zone depends upon the value of earthing resistance and relay setting.

Balanced earth fault protection:

In small-size alternators, the neutral ends of the three-phase windings are often connected internally to a single terminal.

Therefore, it is not possible to use Merz-Price circulating current principle described above because there are no facilities for accommodating the necessary current transformers in the neutral connection of each phase winding.

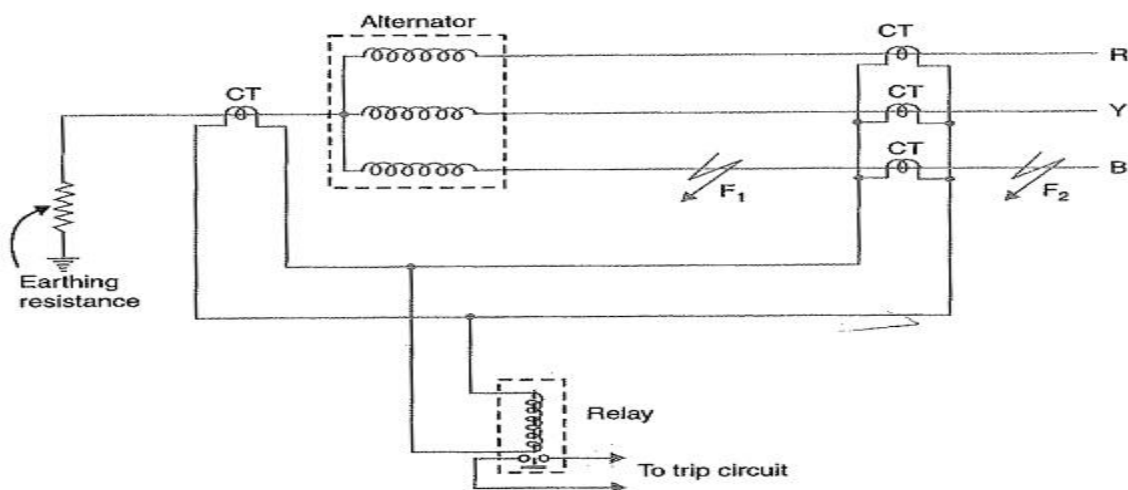

Fig. 22.6

Schematic arrangement:

- ✓ Fig. 22.6 shows the schematic arrangement of a Balanced Earth Fault Protection for a 3-phase alternator.
- ✓ It consists of three line current transformers, one mounted in each phase, having their secondaries connected in parallel with that of a single current transformer in the conductor joining the star point of the alternator to earth.
- ✓ A relay is connected across the transformers secondaries. The protection against earth faults is limited to the region between the neutral and the line current transformers.

Operation:

- ✓ Under normal operating conditions of Balanced Earth Fault Protection, the currents flowing in the alternator leads and hence the currents flowing in secondaries of the line current transformers add to zero and no current flows through the relay.
- ✓ Also under these conditions, the current in the neutral wire is zero and the secondary of neutral current transformer supplies no current to the relay.
- ✓ If an earth-fault develops at F2 external to the protected zone, the sum of the currents at the terminals of the alternator is exactly equal to the current in the neutral connection and hence no current flows through the relay.
- ✓ When an earth-fault occurs at F1 or within the protected zone, these currents are no longer equal and the differential current flows through the operating coil of the relay. The relay then closes its contacts to disconnect the alternator from the system.

Protection Systems for Transformers:

The principal relays and systems used for Protection of Transformers are :

- ✓ **Buchholz devices** providing protection against all kinds of incipient faults i.e. slow-developing faults such as insulation failure of windings, core heating, fall of oil level due to leaky joints etc.
- ✓ **Earth fault relays** providing protection against earth-faults only.
- ✓ **Overcurrent relays** providing protection mainly against phase-to-phase faults and overloading.
- ✓ **Differential system** providing protection against both earth and phase faults.

The complete Protection of Transformers usually requires the combination of these systems. Choice of a particular combination of systems may depend upon several factors such as

- ✓ Size of the trans-former
- ✓ Type of cooling
- ✓ Location of transformer in the network
- ✓ Nature of load supplied and
- ✓ Importance of service for which transformer is required.

Buchholz Relay:

- ✓ Buchholz Relay is a gas-actuated relay installed in oil immersed transformers for protection against all kinds of faults.
- ✓ It is used to give an alarm in case of incipient faults in the transformer and to dis-connect the transformer from the supply in the event of severe internal faults. It is usually installed in the pipe connecting the conservator to the main tank as shown in Fig. 22.11.
- ✓ It is a universal practice to use Buchholz relays on all such oil immersed transformers having ratings in excess of **750 kVA**.

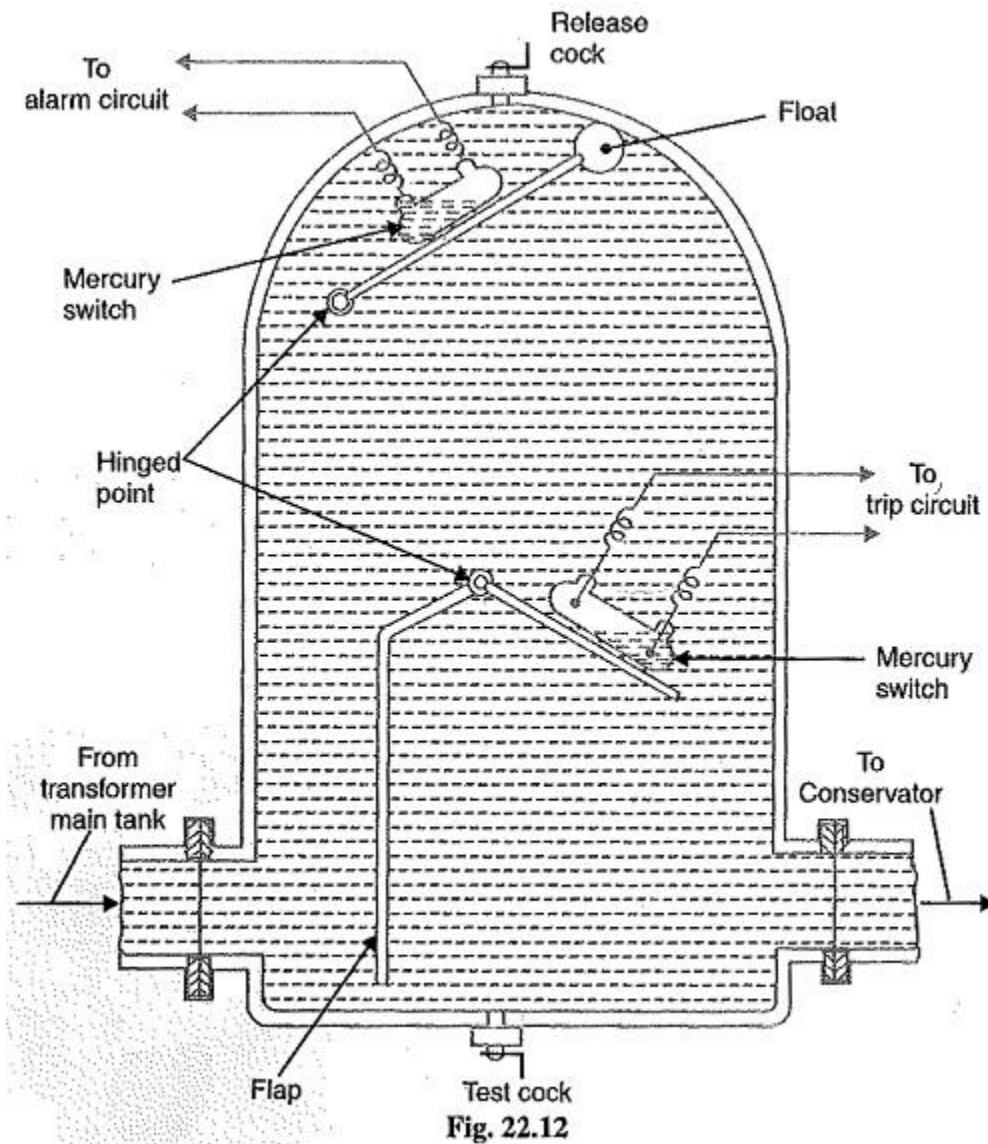

Construction:

- ✓ Fig. 22.12 shows the constructional details of a Buchholz relay. It takes the form of a domed vessel placed in the connecting pipe between the main tank and the conservator.
- ✓ The device has two elements. The upper element consists of a mercury type switch attached to a float.
- ✓ The lower element contains a mercury switch mounted on a hinged type flap located in the direct path of the flow of oil from the transformer to the conservator.
- ✓ The upper element closes an alarm circuit during incipient faults whereas the lower element is arranged to trip the circuit breaker in case of severe internal faults.

Operation:

- ✓ In case of incipient faults within the transformer, the heat due to fault causes the decomposition of some transformer oil in the main tank.
- ✓ The products of decomposition contain more than 70% of hydrogen gas. The hydrogen gas being light tries to go into the conservator and in the process gets entrapped in the upper part of relay chamber.
- ✓ When a pre-determined amount of gas gets accumulated, it exerts sufficient pressure on the float to cause it to tilt and close the contacts of mercury switch attached to it.
- ✓ This completes the alarm circuit to sound an alarm. If a serious fault occurs in the transformer, an enormous amount of gas is generated in the main tank.
- ✓ The oil in the main tank rushes towards the conservator via the Buchholz relay and in doing so tilts the flap to close the contacts of mercury switch.
- ✓ This completes the trip circuit to open the circuit breaker controlling the transformer.

Advantages

- ✓ It is the simplest form of transformer protection.
- ✓ It detects the incipient faults at a stage much earlier than is possible with other forms of protection.

Disadvantages

- ✓ It can only be used with oil immersed transformers equipped with conservator tanks.
- ✓ The device can detect only faults below oil level in the transformer. Therefore, separate protection is needed for connecting cables.

Busbar Protection:

Busbars and lines are important elements of electric power system and require the immediate attention of protection engineers for safeguards against the possible faults occurring on them.

The two most com-monly used schemes for busbar protection are:

1. Differential Protection
2. Fault Bus Protection

1. Differential Protection: The basic method for busbar protection is the differential scheme in which currents entering and leaving the bus are totalized. During normal load condition, the sum of these currents is equal to zero. When a fault occurs, the fault current upsets the balance and produces a differential current to operate a relay.

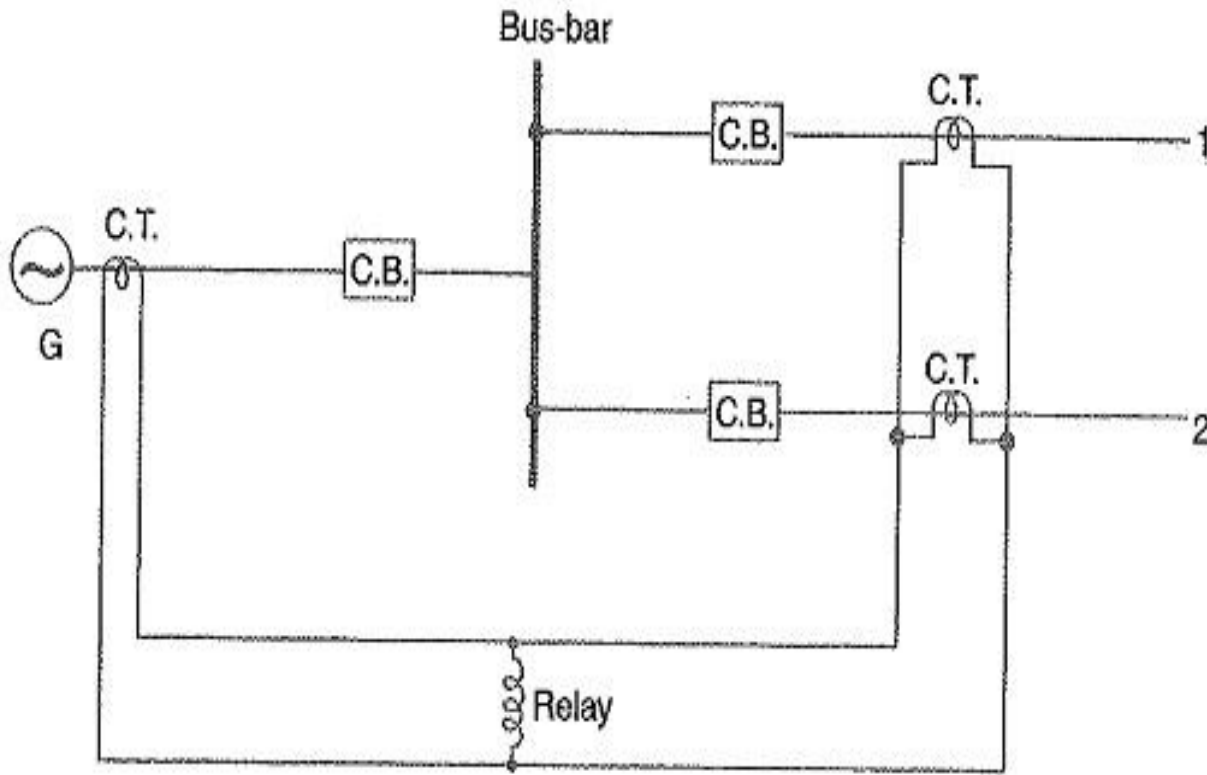

Fig. 23.1

- ✓ Fig. 23.1 shows the single line diagram of current differential scheme for a station busbar. The Busbar Protection is fed by a generator and supplies load to two lines.
- ✓ The secondaries of current transformers in the generator lead, in line 1 and in line 2 are all connected in parallel. The protective relay is connected across this parallel connection.
- ✓ All CTs must be of the same ratio in the scheme regardless of the capacities of the various circuits. Under normal load conditions or external fault conditions, the sum of the currents entering the bus is equal to those leaving it and no current flows through the relay.
- ✓ If a fault occurs within the protected zone, the currents entering the bus will no longer be equal to those leaving it. The difference of these currents will flow through the relay and cause the opening of the generator, circuit breaker and each of the line circuit breakers.

2. Fault Bus Protection:

It is possible to design a station so that the faults that develop are mostly earth-faults. This can be achieved by providing earthed metal barrier (known as fault bus) surrounding each conductor throughout its entire length in the bus structure. With this arrangement, every fault that might occur must involve a connection between a conductor and an earthed metal. By directing the flow of earth-fault current, it is possible to detect the faults and determine their location. This type of protection is known as fault bus protection.

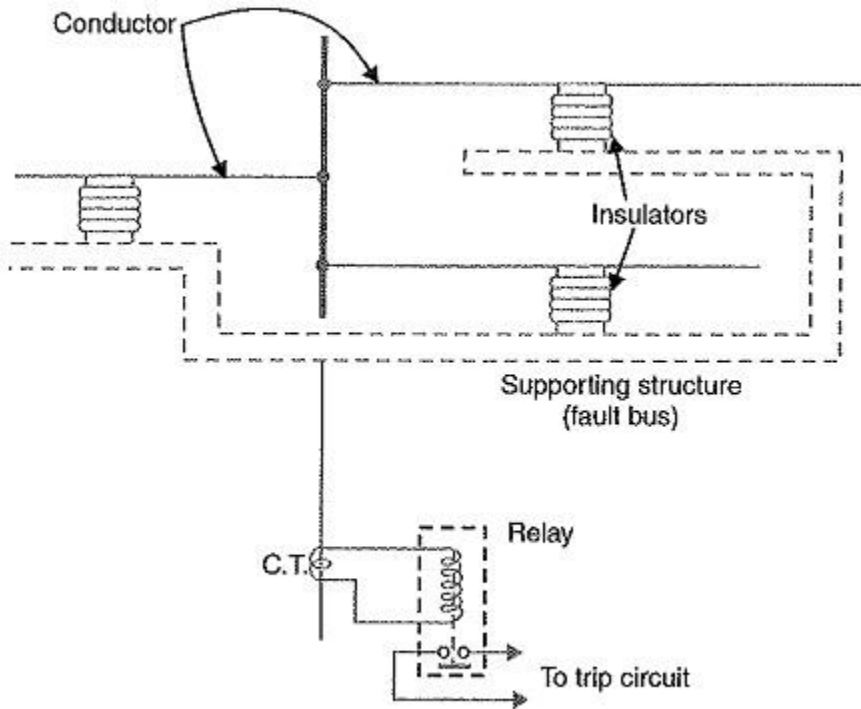

Fig. 23.2

Protection of Transmission line:

The probability of faults occurring on the lines is much more due to their greater length and exposure to atmospheric conditions. This has called for many protective schemes which have no application to the comparatively simple cases of alternators and transformers. The requirements of line protection are:

- ✓ In the event of a short-circuit, the circuit breaker closest to the fault should open, all other circuit breakers remaining in a closed position.
- ✓ In case the nearest breaker to the fault fails to open, back-up protection should be provided by the adjacent circuit breakers.
- ✓ The relay operating time should be just as short as possible in order to preserve system stability, without unnecessary tripping of circuits.

The protection of lines presents a problem quite different from the protection of station apparatus such as generators, transformers and Busbar Protection. While differential protection is ideal method for lines, it is much more expensive to use. The two ends of a line may be several kilometers apart and to compare the

two currents, a costly pilot-wire circuit is required. This expense may be justified but in general less costly methods are used. The common methods of line protection are :

- ✓ Time-graded overcurrent protection
- ✓ Differential protection
- ✓ Distance protection



Fig. 23.3

Fig. 23.3 shows the symbols indicating the various types of relays.

Merz-Price voltage balance system:

- ✓ Fig. 23.8 shows the single line diagram of Merz-Price voltage balance system for the protection of a 3-phase line. Identical current transformers are placed in each phase at both ends of the line.
- ✓ The pair of CTs in each line is connected in series with a relay in such a way that under, normal conditions, their secondary voltages are equal and in opposition i.e. they balance each other.

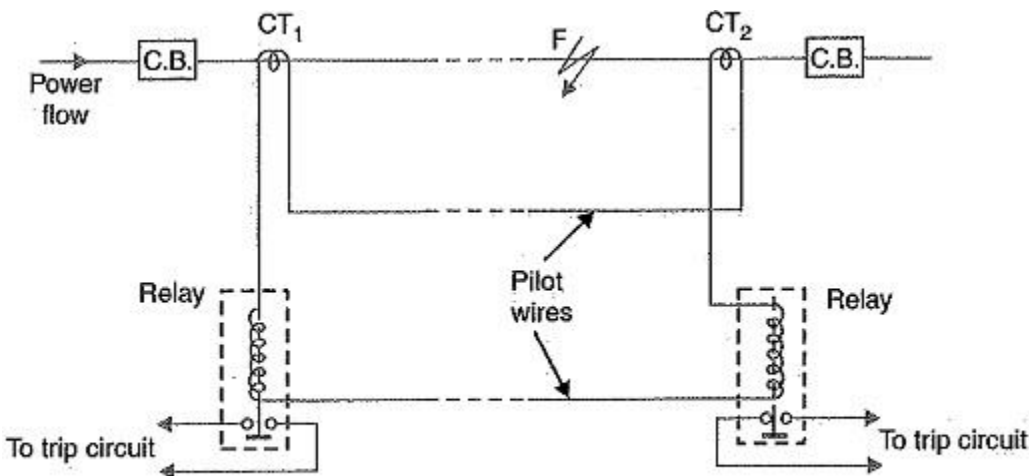

Fig. 23.8

- ✓ Under healthy conditions, current entering the line at one-end is equal to that leaving it at the other end.
- ✓ Therefore, equal and opposite voltages are induced in the secondaries of the CTs at the two ends of the line. The result is that no current flows through the relays.
- ✓ Suppose a fault occurs at point F on the line as shown in Fig. 23.8. This will cause a greater current to flow through CT1 than through CT2. Consequently, their secondary voltages become unequal and circulating current flows through the pilot wires and relays.
- ✓ The circuit breakers at both ends of the line will trip out and the faulty line will be isolated.

Fig. 23.9 shows the connections of Merz-Price voltage balance scheme for all the three phases of the line.

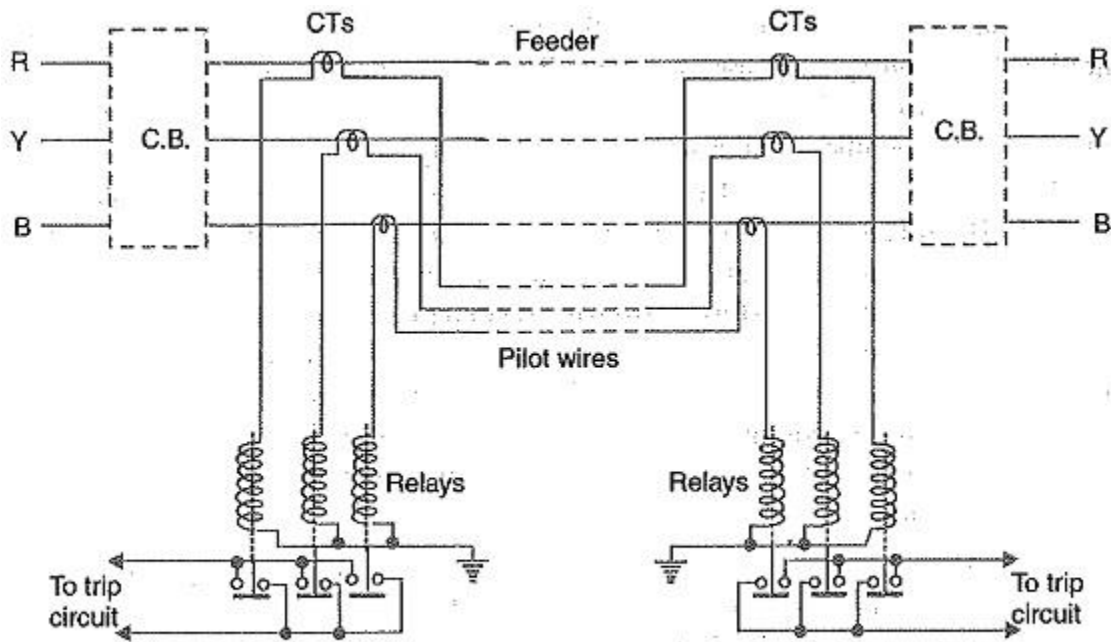

Fig. 23.9

Advantages

- ✓ This system can be used for ring mains as well as parallel feeders,
- ✓ This system provides instantaneous protection for ground faults. This decreases the possibility of these faults involving other phases.
- ✓ This system provides instantaneous relaying which reduces the amount of damage to overhead conductors resulting from arcing faults.

Disadvantages

- ✓ Accurate matching of current transformers is very essential.
- ✓ If there is a break in the pilot-wire circuit, the system will not operate.
- ✓ This system is very expensive owing to the greater length of pilot wires required.

Feeder Protection:

Feeder protection is defined as the protection of the feeder from the fault so that the power grid continues to supply the energy. The feeder injects the electrical energy from the substation to the load end.

The main requirements of the feeder protection are;

- During the short circuit, the circuit breaker nearest to the fault should open and all other circuit breakers remain in a closed position.
- If the breaker nearest to the fault fails to open then, backup protection should be provided by the adjacent circuit breaker.

- The relay operating time should be small to maintain the system stability without necessary tripping of a circuit.

Protection of Radial Feeders-

In a radial system when the number of feeders is connected in series as shown in the figure.

- When the fault occurs on the SS4, the relay OC5 should operate first and not any other i.e. the time require to operate the relay OC4 must be less than the time required for relay OC3 and so on.
- This shows that the time setting required for these relays must be properly graded. The minimum interval of time which can be allowed for the two adjacent circuit breaker depends on its own clearance time, plus a small time for the safety margin.
- With normal circuit breaker in use minimum, the discriminating time between adjacent breaker should be about 0.4 seconds. The time settings for relay OC1, OC2, OC3, OC4, and OC5 will be 0.2 seconds, 1.5 seconds, 1.5 seconds, 1.0 seconds, 0.5 second and instantaneous respectively.
- Along with the grading system, it is also essential that the time of operation for the severe fault should be less. This can be done by using time limiting fuse in parallel with the trip coils

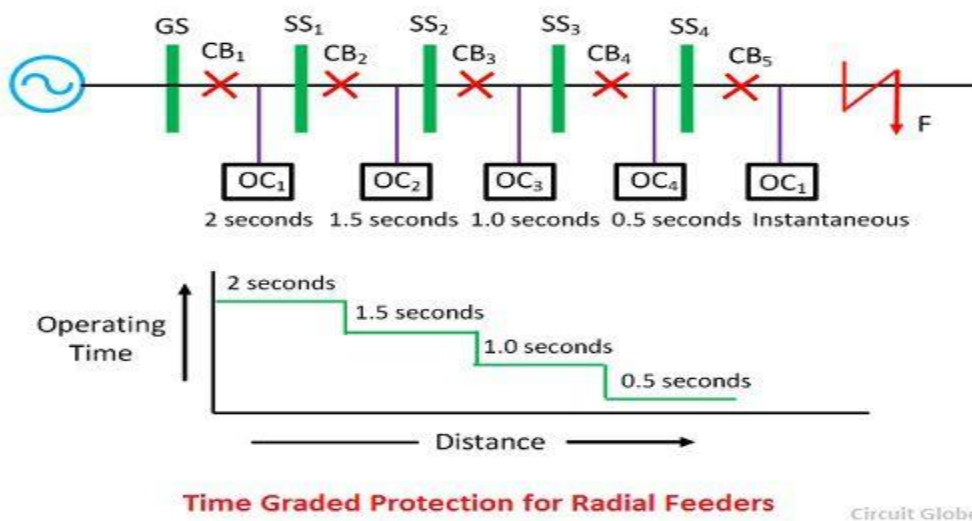

Protection of Parallel Feeders

- The parallel connection of the supply is mainly used for the continuity of the supply and for sharing the load. When the fault occurs on the protective feeder, the protective device will select and isolate the defective feeder while the other instantly assume the increased load.
- When the heavy fault F occur on any one of the lines, then the power is fed into fault from the sending end as well as from the receiving end of the line. The direction of power flow will be reversed through the relay on D, which will be open.
- The excess current is then restricted to B until its overload relay operates and trips the circuit breaker, thus completely isolating the faulty feeder and supplying power through the healthy feeder. This method is only satisfactory when the fault is heavy and reverse the power at D.

Hence differential protection is also added along with the overloaded protection at both the end of the line.

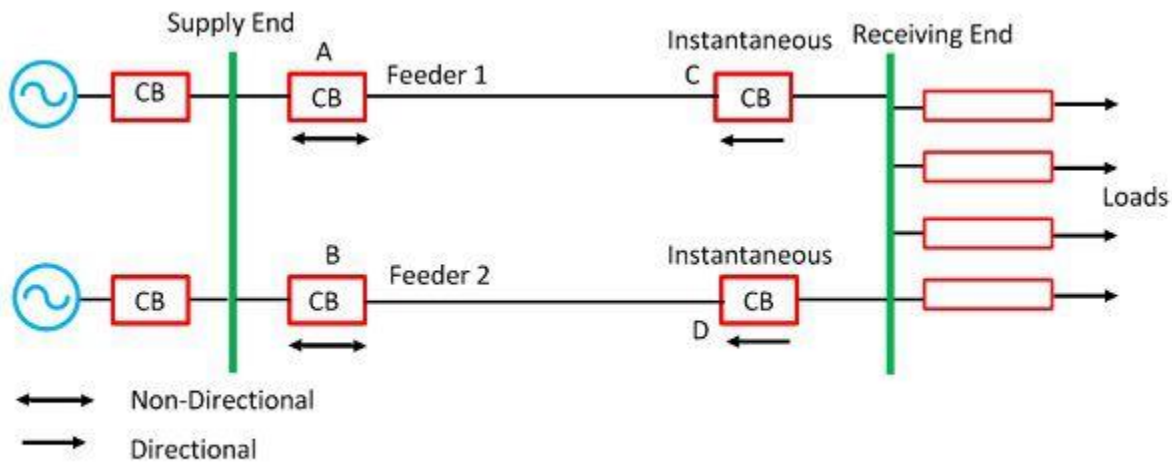

Protection of Parallel Feeders

Circuit Globe

Protection of Ring Main System

The ring main is a system of interconnection between a series of the power station by a different route. In the main ring system, the direction of power can be changed at will, particularly when the interconnection is used.

The elementary diagram of such a system is shown in the figure below where G is the generating station, and A, B, C, and D are substation. At the generating station, the power flow only in one direction and hence no time lag overload relays is used. The time grade overload relay is placed at the end of the substation, and it will trip only when overload flows away from the substation which they protect.

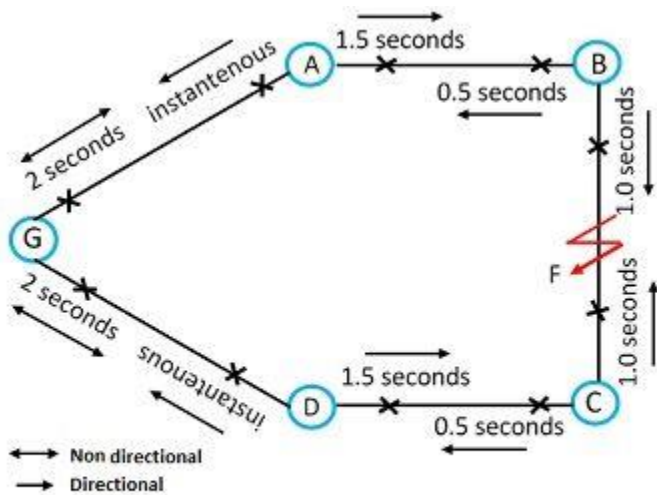

Protection of Ring System

Circuit Globe

Going round the ring in the direction GABCD the relay on the further side of each station are set with decreasing time lags. At generating station 2 seconds at station A, B, C and 1.5 seconds, 1.0 second, 0.5 second and instantaneous respectively. Similarly going round the ring in the opposite direction the relay on the outgoing sides would be set as follows.

If the fault occurs at point F, the power F is fed into the fault through two paths ABF and DCF. The relay to operate is that between substation B and fault point F and substation C and fault point F. Thus the fault on any section will cause the relay on that section to operate, and the healthy section will be operating uninterruptedly.

.....

UNIT-7

PROTECTION AGAINST OVER VOLTAGE AND LIGHTING

Definition: Voltage surge is defined as the sudden rise in excessive voltage which damages the electrical equipment of an installation. The overvoltage in the lines occurs because of a rise in voltage between both phases and between phase and ground. The voltage surges are mainly classified under two heading; internal and external voltages.

Types of Voltage Surge

The overvoltage in the power station can be caused either by the internal disturbance or by the atmospheric eruption. On the basis of the generation of overvoltages the voltage surge are classified into two categories. These are

1. Internal Overvoltage
2. External Overvoltage

Internal Overvoltage

When the voltage in the system raises itself beyond the rated voltage, then such type of voltage is called internal overvoltage. The internal voltage may be transient, dynamic or stationary in nature. If the overvoltage wave is transient in nature, then there frequency is unrelated to the normal frequency, and it will persist few cycles only.

The internal overvoltage mainly causes because of the following reasons;

Switching Operation on Unloaded Line – During the switching operation, the line is connected to a source of voltage and travelling waves are set up which rapidly charge the line. These waves instantly attained the voltage of the magnitude not exceeding twice the supply voltage at the instant of disconnection.

Sudden Opening of Load Line – When the load on the line is suddenly opened a transient voltage of the value of $e = i Z_0$ is set up, where i is the instantaneous value of the current at the instant of opening of the line and Z_0 is the natural or the surge impedance of the line. The transient overvoltage of the line does not depend on the line voltage and therefore low voltage transmission system is liable to overvoltage of the same magnitude as compared to high voltage system.

Insulation Failure – The failure of insulation between the line and the earth is very frequent. When the insulation breakdown occurs the potential at fault suddenly falls from maximum to zero and therefore a negative voltage wave of very steep front in the form of surges are generated in both directions.

External Overvoltages

The overvoltage which is caused by the atmospheric discharge such as static discharge or lightning strokes such type of voltage is called external overvoltage. External overvoltage can cause considerable stress on the insulation. The intensity of the voltages is varied in the case of the lightning.

The intensity of lightning depends on the how directly the line is struck, i.e., directly by the main discharge, directly by a branch or streamer, or by the induction due to a flash passing near to but not touching the line.

The installation in the power station is mainly classified into two types the one which is electrically exposed, resulting in the apparatus being subjected to overvoltages of the atmospheric origin and another which is electrically non-exposed and therefore not subject to this type of overvoltage.

Lightning Stroke

Definition: Lightning stroke is the direct discharge of an electrical charge between the atmosphere and the object of earth. It is a sudden flow of electric charge between the electrical charge area of a cloud also called intra-cloud and another cloud called (CC lightning) or between the charged cloud and the ground (CG lightning).

Mechanism of the Lightning Discharge:

In the atmosphere, the positive, as well as the negative ions in the air, attach themselves to the small dust particles. The water drops present in the air also get charged because of polarization by induction. These charged particles and water drops charged the clouds. The positive ions are collected in the upper region, and the negative ions are collected in the lower region of the cloud because of their mass.

The potential gradient of the clouds is not uniform, and it is of the order of 10 – 30 KV/cm in any part of the cloud. The initial discharge which is also called pilot discharge or pilot leader moves slowly towards it from the earth.

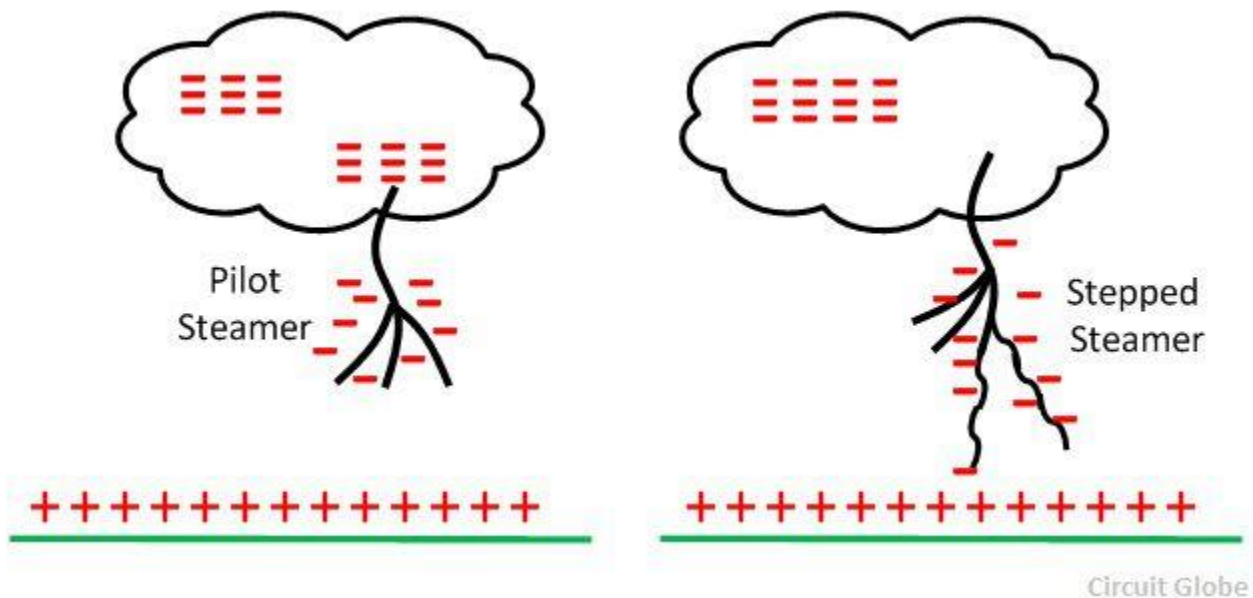

The first discharge moves to earth in steps of about 50 meters each and is, therefore, termed the stepped leader. The pilot leader carries a charge with it, and the potential gradient at its tips is very high. It ionises the air and provides a path or channel for the pilot leader.

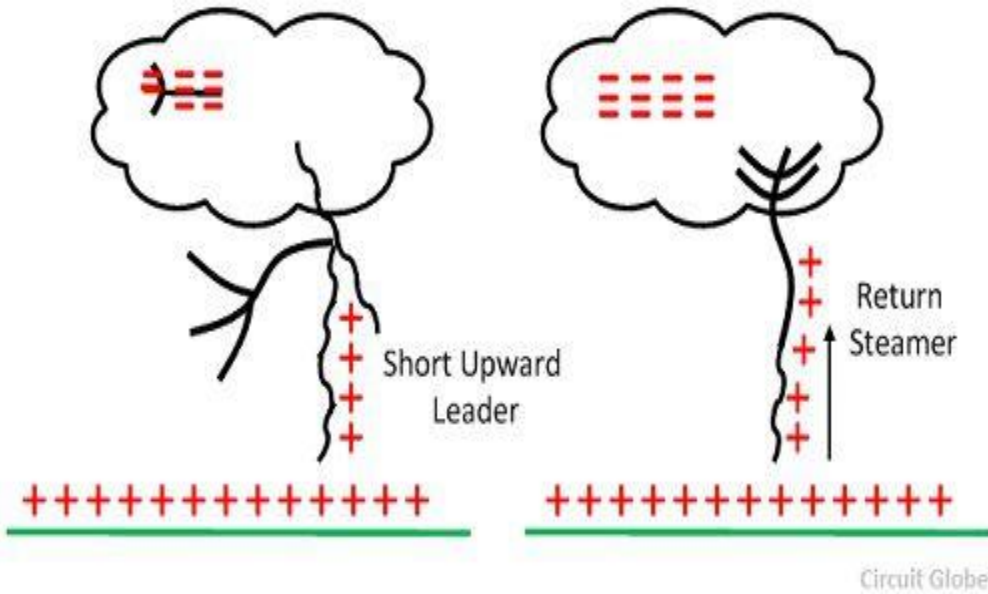

When the pilot steamer reaches near the earth, the electric field intensity increases and due to this, the charges of an opposite polarity in the form of a short steam rises from the earth to meet the tip of downward leader. When a contact is made between the pilot leader and the short upward steamer, a return steamer travel from the earth to cloud along the ionized channel formed by the pilot leader. The return steamer moves very fast and produces the well known, intensely luminous lightning flash.

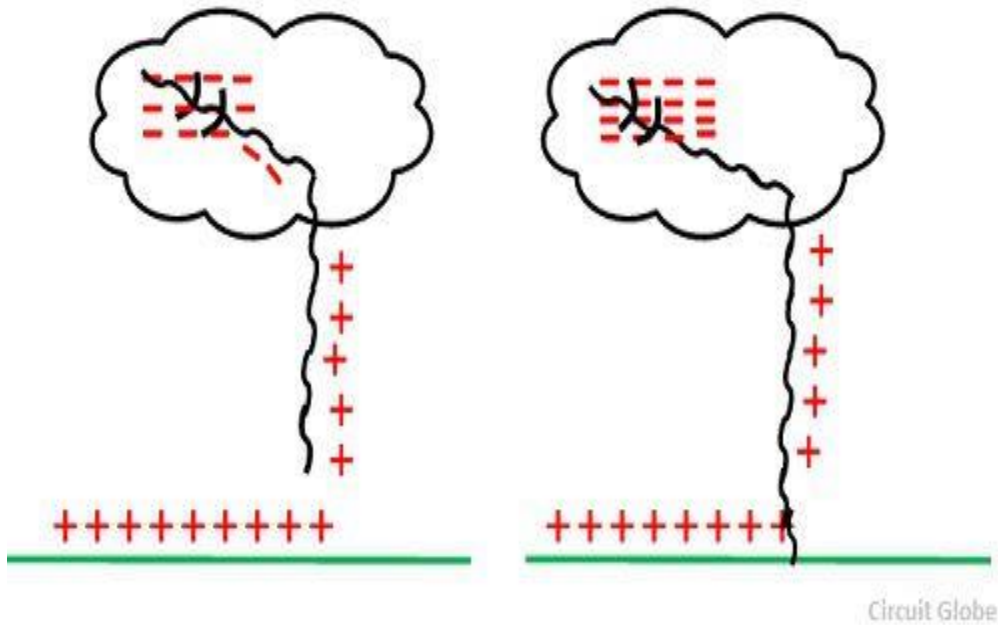

The potential of the portion of the cloud from where the discharge originated is lowered by the passage of the charge through the ionized channel to the earth. But the other portion of the clouds remains charged. Therefore, a high potential develops between the original charge Centre and another charge center in the clouds.

The stroke of lightning has a low current but long duration. It causes the fire when it strokes on the object. The stroke of cold, lightning has a high current, but it is of short duration.

Types of lightning strokes:

1. Direct stroke
2. Indirect stroke

Direct stroke:

In the direct stroke, the lightning discharge (i.e. current path) is directly from the cloud to the subject equipment e.g. an overhead line. From the line, the current path may be over the insulators down the pole to the ground. The overvoltages set up due to the stroke, may be large enough to flashover this path directly to the ground. The direct strokes can be of two types viz. (i) Stroke A and (ii) stroke B.

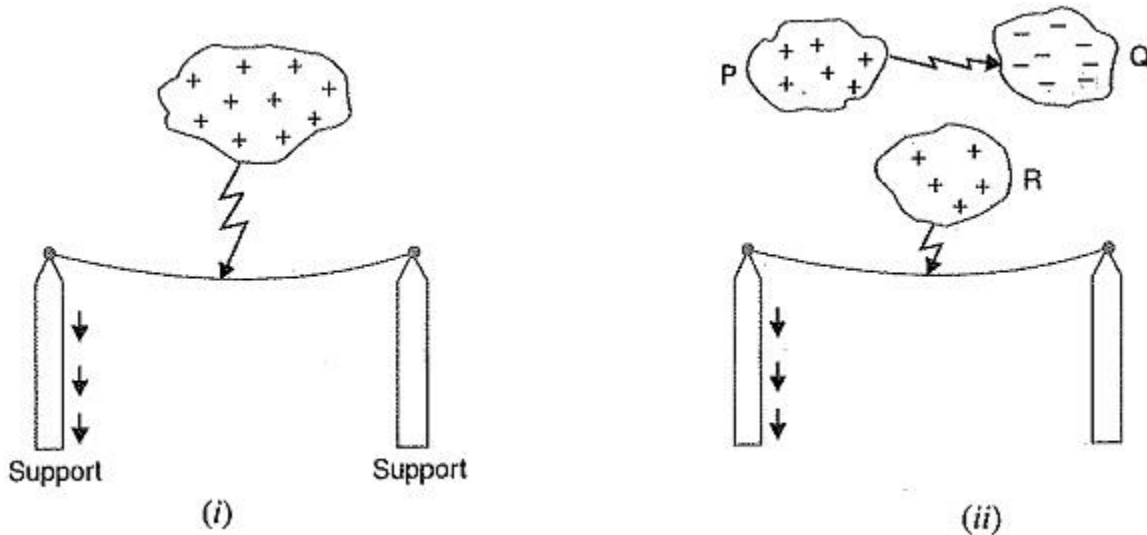

Fig. 24.5

(i) In stroke A, the lightning discharge is from the cloud to the subject equipment i.e. an over-head line in this case as shown in Fig. 24.5 (1). The cloud will induce a charge of opposite sign on the tall object (e.g. an overhead line in this case). When the potential between the cloud and line exceeds the breakdown value of air, the lightning discharge occurs between the cloud and the line.

(ii) In stroke B, the lightning discharge occurs on the overhead line as a result of stroke A between the clouds as shown in Fig. 24.5 (ii). There are three clouds P, Q and R having positive, negative and positive charges respectively. The charge on the cloud Q is bound by the cloud R. If the cloud P shifts too near the cloud Q, then lightning discharge will occur between them and charges on both these clouds disappear quickly. The result is that charge on cloud R suddenly becomes free and it then discharges rapidly to earth, ignoring tall objects.

Indirect stroke: Indirect strokes result from the electrostatically induced charges on the conductors due to the presence of charged clouds. This is illustrated in Fig. 24.6.

A positively charged cloud is above the line and induces a negative charge on the line by electrostatic induction. This negative charge, however, will be only on that portion of the line right under the cloud and the portions of the line away from it will be positively charged as shown in Fig. 24.6. The induced positive

charge leaks slowly to earth via the insulators. When the cloud discharges to earth or to another cloud, the negative charge on the wire is isolated as it cannot flow quickly to earth over the insulators. The result is that negative charge rushes along the line in both directions in the form of travelling waves. It may be worthwhile to mention here that majority of the surges in a transmission line are caused by indirect Types of Lightning Strikes strokes.

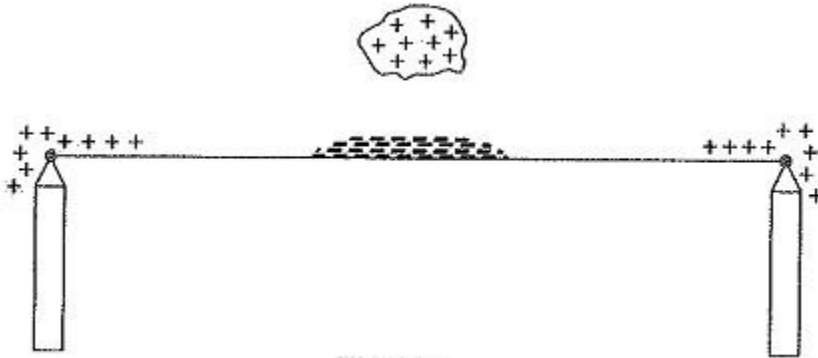

Fig. 24.6

Harmful Effects of Types of Lightning Strikes:

A direct or indirect lightning stroke on a transmission line produces a steep-fronted voltage wave on the line. The voltage of this wave may rise from zero to peak value (perhaps 2000 kV) in about $1 \mu\text{s}$ and decay to half the peak value in about $5 \mu\text{s}$. Such a steep-fronted voltage wave will initiate travelling waves along the line in both directions with the velocity dependent upon the L and C parameters of the line.

- (i) The travelling waves produced due to lightning surges will shatter the insulators and may even wreck poles.
- (ii) If the travelling waves produced due to Types of Lightning Strikes hit the windings of a transformer or generator, it may cause considerable damage. The inductance of the windings opposes any sudden passage of electric charge through it. Therefore, the electric charges “pile up” against the transformer (or generator).
- (iii) If the arc is initiated in any part of the power system by the lightning stroke, this arc will set up very disturbing oscillations in the line. This may damage other equipment connected to the line.

Lightning arresters:

Definition: The device which is used for the protection of the equipment at the substations against travelling waves, such type of device is called lightning arrester or surge diverter.

Working of Lightning Arrester

- When a travelling wave reaches the arrester, it sparks over at a certain prefixed voltage as shown in the figure below. The arrester provides a conducting path to the waves of relatively low impedance

between the line and the ground. The surge impedance of the line restricts the amplitude of current flowing to ground.

- The lightning arrester provides a path of low impedance only when the travelling surge reaches the surge diverter, neither before it nor after it. The insulation of the equipment can be protected if the shape of the voltage and current at the diverter terminal is similar to the shape shown below.

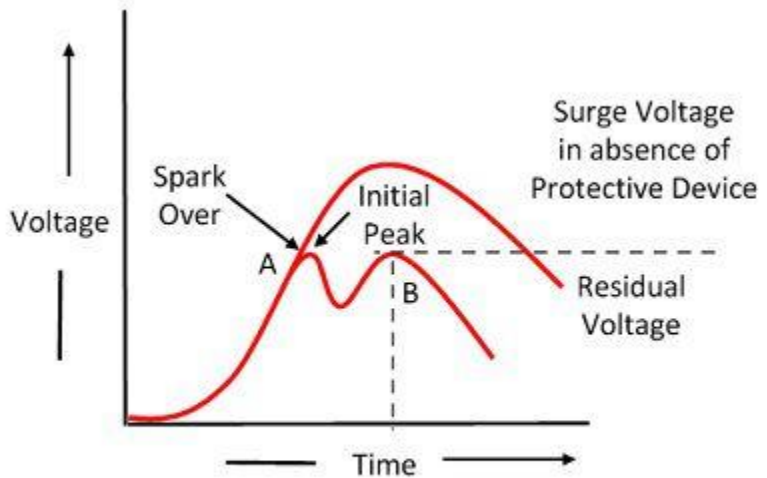

Voltage Characteristic

Circuit Globe

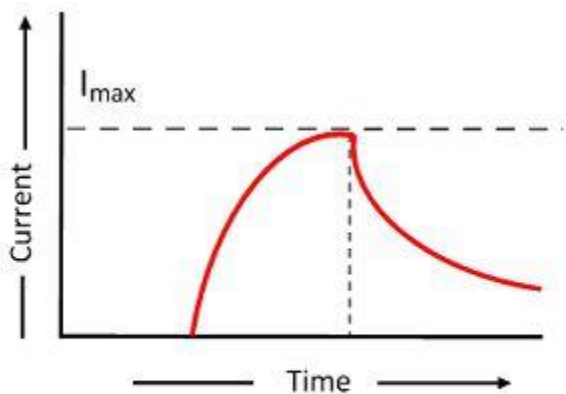

Current Characteristic

Circuit Globe

Rod Gap Arrester-

- ✓ It is one of the simplest forms of the arrester. In such type of arrester, there is an air gap between the ends of two rods.
- ✓ The one end of the arrester is connected to the line and the second end of the rod is connected to the ground.
- ✓ The gap setting of the arrester should be such that it should break before the damage. When the high voltage occurs on the line, the gap sparks and the fault current passes to the earth.
- ✓ Hence the equipment is protected from damage. The difficulty with the rod arrester is that once the spark having taken place it may continue for some time even at low voltages.

- ✓ To avoid it a current limiting reactor in series with the rod is used.
- ✓ The resistance limits the current to such an extent that it is sufficient to maintain the arc.
- ✓ Another difficulty with the rod gap is that the rod gap is liable to be damaged due to the high temperature of the arc which may cause the rod to melt.

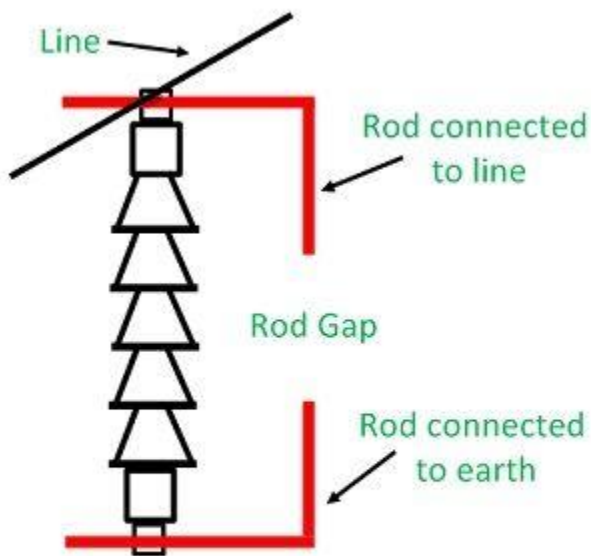

Rod gap on an insulator string

Circuit Globe

Horn-gap arrester-

- ✓ As the name suggests, this arrester has two metal rods in horn-shaped. The arrangement of these metal rods can be done around a small air gap.
- ✓ The distance between these two rods can be increased because they increase from the gap. The metal rods are located on ceramic insulators.
- ✓ The connection of the horn can be done by connecting it to two dissimilar wires. One side of the horn can be connected to the line throughout a resistance & choke coil whereas the other side is grounded efficiently.

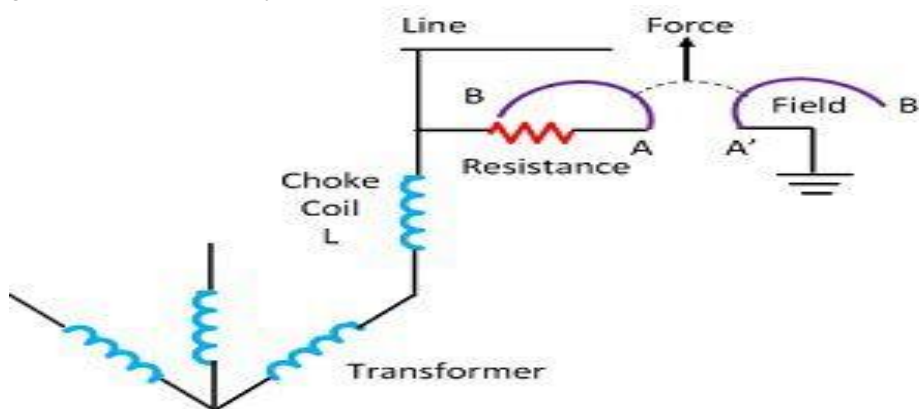

Horn Gap With Choke Coil and Resistance

Circuit Globe

- ✓ The resistance restricts the flow of current toward a minute value. The choke coil is used to provide less reactance at the usual power frequency and also provides high reactance at transient frequency.
- ✓ Therefore the choke coil doesn't permit the transients to go into the apparatus to be protected. The gap among the horns can be adjusted so that the usual supply voltage is not sufficient to cause an arc.

Valve type arrester-

- ✓ Such type of resistor is called nonlinear diverter. It essentially consists a divided spark gap in series with a resistance element having the nonlinear characteristic.

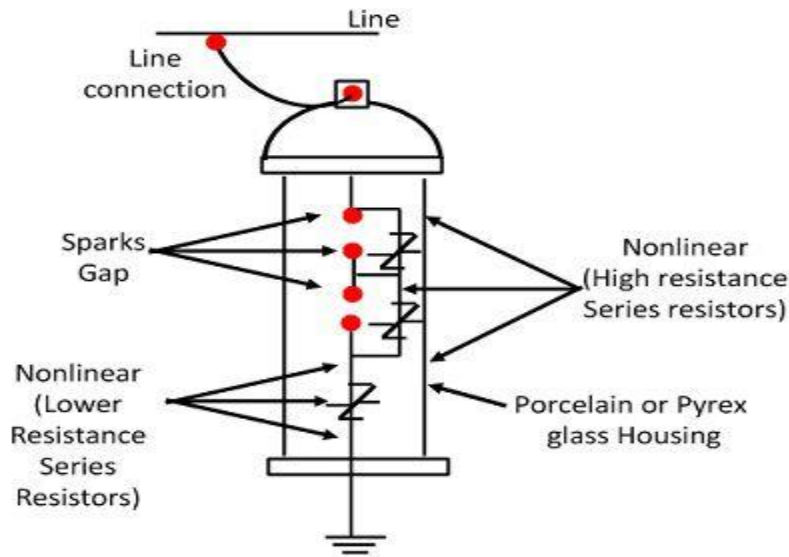

Valve Type Lightning Arrester

Circuit Globe

- ✓ The divided spark gap consists of some identical elements coupled in series. Each of them consists two electrodes with the pre-ionization device. Between each element, a grading resistor of high ohmic value is connected in parallel.

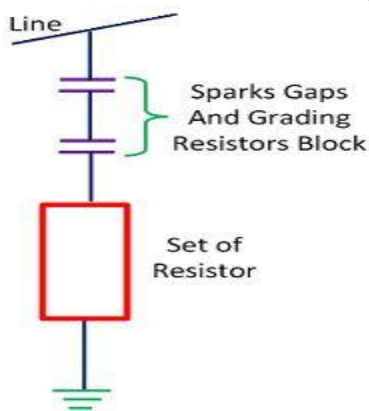

Valve Type Lightning Arrester

Circuit Globe

- ✓ During the slow voltage variations, there is no sparks-over across the gap. But when the rapid change in voltage occurs, the potential is no longer evenly graded across the series gap.

- ✓ The influence of unbalancing capacitance between the sparks gaps and the ground prevails over the grounded resistance. The impulse voltage is mainly concentrated on the upper spark gap which in spark over cause the complete arrester to spark over to.

Types of Surge Absorber:

A surge absorber is a protective device which reduces the steepness of wave front of a surge by ab-sorbing surge energy.

Different Types of Surge Absorber are

1. Condenser or Capacitor Surge Absorber
2. Inductor and Resistance Surge Absorber
3. Ferranti Surge Absorber

1. Condenser or Capacitor Surge Absorber:

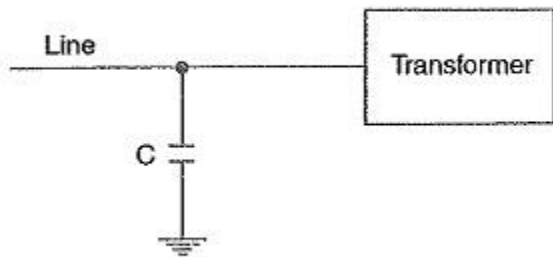

Fig. 24.14

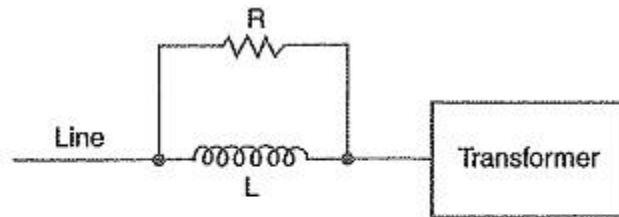

Fig. 24.15

A condenser connected between the line and earth can act as a surge absorber. Fig. 24.14 shows how a capacitor acts as surge absorber to protect the transformer winding. Since the reactance of a condenser is inversely proportional to frequency, it will be low at high frequency and high at low frequency. Since the surges are of high frequency, the capacitor acts as a short circuit and passes them directly to earth. However, for power frequency, the reactance of the capacitor is very high and practically no current flows to the ground.

2. Inductor and Resistance Surge Absorber:

Another Types of Surge Absorber consists of a parallel combination of choke and resistance connected in series with the line as shown in Fig. 24.15. The choke offers high reactance to surge frequencies ($X_L = 2\pi fL$). The surges are, therefore, forced to flow through the resistance R where they are dissipated.

3. Ferranti Surge Absorber:

Fig 24.16 shows the Types of Surge Absorber. It is called Ferranti surge absorber. It consists of an air cored inductor connected in series with the line. The inductor is surrounded by but insulated from an earthed metallic sheet called dissipator.

This arrangement is equivalent to a transformer with short-circuited secondary. The inductor forms the primary whereas the dissipator forms the short-circuited secondary.

The energy of the surge is used up in the form of heat generated in the dissipator due to transformer action. This type of surge absorber is mainly used for the protection of transformers.

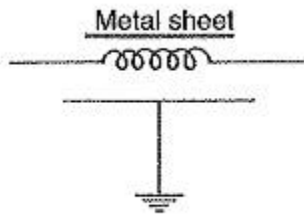

Fig. 24.16

UNIT-8

STATIC RELAY

Definition: The relay which does not contain any moving parts is known as the static relay. In such type of relays, the output is obtained by the static components like magnetic and electronic circuit etc. The relay which consists static and electromagnetic relay is also called static relay because the static units obtain the response and the electromagnetic relay is only used for switching operation.

Advantages of Static Relay

The following are the benefits of static relays.

1. The static relay consumes very less power because of which the burden on the measuring instruments decreases and their accuracy increases.
2. The static relay gives the quick response, long life, high reliability and accuracy and it is shockproof.
3. The reset time of the relay is very less.
4. It does not have any thermal storage problems.
5. The relay amplifies the input signal which increases their sensitivity.
6. The chance of unwanted tripping is less in this relay.
7. The static relay can easily operate in earthquake-prone areas because they have high resistance to shock.

Instantaneous Overcurrent Relays-

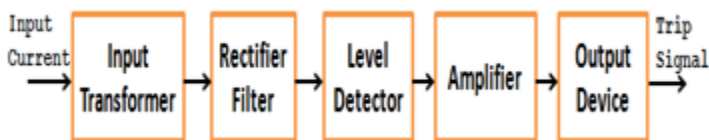

- ✓ The block schematic diagram of the static instantaneous Overcurrent relay is shown in the figure.
- ✓ The current derived from the CT is fed to the input transformer which gives a proportional output voltage.
- ✓ The input transformer has an air gap in the iron core to give linearity in the current / voltage relationship up to the highest value of current expected and is provided with tapping on its secondary winding to obtain different current settings.
- ✓ The output voltage of the transformer is rectified through a rectifier and then filtered at a single stage to avoid undesirable time delay in filtering, so as to ensure high speed of operation.
- ✓ A limit made of a zener diode is also incorporated in the circuit to limit the rectified voltage to safe values even when the input current is very high under fault conditions. A fixed portion of the rectified and filtered voltage (through a potential divider) is compared against a preset pick-up value

by a level detector and if it exceeds the pick-up value, a signal through an amplifier is given to the output which issues the trip signal.

- ✓ The output device may either be a static thyristor circuit or an electromagnetic slave relay.

IDMT relay:

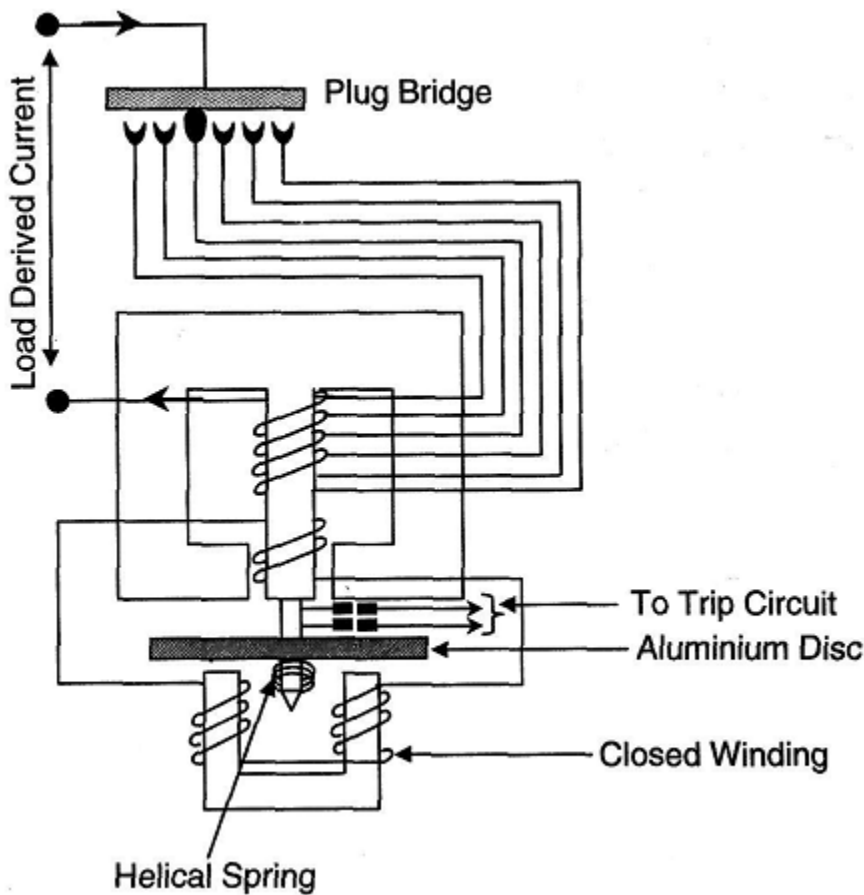

- ✓ Accurate inverse time delay characteristics are provided by an induction type relay constructed similar to that of a domestic wattmeter or reverse power relay.
- ✓ Current in the main winding is obtained through a current transformer from the alternator input to the switchboard. The main winding is tapped and the taps are brought out to a plug bridge for selection of different settings.
- ✓ Alternating current in the main winding on the Centre leg of the upper laminated iron core produces a magnetic field that in turn induces current in the closed winding.
- ✓ The magnetic field associated with the closed winding is displaced from the magnetic field of the main winding and the effect on the aluminum disc is to produce changing eddy currents in it.
- ✓ The tendency for the disc to rotate is prevented by a helical restraining spring when normal current is flowing. Excessive current causes rotation against the spring. A moving contact on the spindle rotates about half a turn. The two fixed contacts are bridged and the tripping circuit is closed.

.....END.....